

ON MICROMETRIC PATTERN FORMATION IN MAGNETIC FLUIDS THIN FILMS

G. Fosa, G. Strat, R. Badescu, Gh. Calugaru*

“Gh. Asachi” Technical University, Department of Physics, 63 Mangeron Blvd.,
Iași-700050, Romania

The patterns of transformer-oil magnetic fluid films in applied parallel and perpendicular magnetic fields were studied. For the magnetic field applied parallel to film some interesting optical phenomena have been observed, such as birefringence and dichroism. We report some measurement results on time dependence of the transmittances both of ordinary rays and of extraordinary rays passing perpendicular through the sample, after suddenly applying or removing the magnetic field. For the magnetic field applied transversally to film we observed and studied by optical microscopy the hexagonal structure in a weaker perpendicular field, and the labyrinthine pattern in a stronger perpendicular field.

(Received April 26, 2004; accepted June 3, 2004)

Keywords: Magnetic fluids, Agglomeration, Anisotropy, Transmittance, Diffraction

1. Introduction

Due to their rich phenomena, the structures of magnetic fluid films under external magnetic fields have attracted the interest of many scientists. Some investigators have shown versatile structural patterns in magnetic fluid films under external magnetic fields [1–4]. From these have been remarked one-dimensional patterns formed under the influence of fields oriented parallel to the plane of films (parallel fields) and two-dimensional lattices formed under the influence of fields oriented perpendicular to the plane of the films (perpendicular fields). Furthermore, it has been indicated that the structures can induce many significant optical properties [5–7]. From these are remarking the magnetically induced birefringence and dichroism of magnetic fluid films under parallel magnetic fields, attributed to the formation of microclusters and macroclusters distributed periodically in the plane of films, and the magnetochromatic effects in perpendicular magnetic fields, attributed to the formation of ordered hexagonal structures of magnetic columns perpendicularly on the films.

All the above effects depend significantly on the nature and physical properties of magnetic fluids [8]. In this work we investigate their structures by optical microscopy observations and polarization, transmittance and spectral measurements on transformer oil base magnetic fluids.

2. Experimental details

The studied magnetic fluid was a transformer oil base ferrofluid, containing nanoparticles of Fe_3O_4 obtained by the coprecipitation technique and stabilized with chemically pure oleic acid. The particles size was around 9 nm and the saturation magnetization of the sample was 28 kA/m (volume fraction of magnetite of 10 %). A micro drop of magnetic fluid was poured in a circular glass cell with diameter of 5 mm and thickness of 10 μm , and then covered by a plane glass plate. To study the macro-cluster formation and their time evolution, photo images of the magnetic fluid film were taken by using an IOR optical microscope and recorded in a personal computer through a CCD

* Corresponding author: gcalug@phys.tuiasi.ro

video camera. In this stage an unpolarized white light was transmitted through the film. The cell in the magnetic fluid film sample laid on a heat-insulating bored plate mounted on the microscope table in the center of a system of two face-to-face rectangular coils. The coils are able to generate a magnetic field with a non-uniformity of about 1% on the magnetic fluid film width, at an intensity of maximum 40 kA/m.

To study the transmissivity of magnetic fluid films we have built a set-up similar to those of Taketomi et al. [9] (Fig. 1). The light source used by us was a He-Ne laser (S) of 25 mW and 650 nm wavelength. The emitted light is linearly polarized, the polarization direction being considered as the direction of the electric displacement vector of the ray. The laser beam propagates in the x-direction, passes through a linear polarizer (P) and is normal-incident to the film (MF). The beam emerging along the incident beam direction is received by a photo detector (D_1). In order to compensate the laser emission fluctuations and to have a reference, the beam is splitted before the polarizer, the reflected beam by the splitter (M) being received by the second photo detector (D_2). The signals from photo detectors are transmitted to a data acquisition board on a personal computer for storage and processing. The transmissivity is obtained as the ratio of the transmitted light intensity measured by D_1 to the reference light intensity measured by D_2 . The magnetic field in this set-up is generated by a pair of Helmholtz coils (HC) in the y-direction. The non uniformity of the field intensity is less than 0.1 % in a volume of 1 cm^3 at the center of coils system. The maximum field intensity is 60 kA/m, the corresponding transient time being of maximum 0.5 s. In the absence of magnetic field the transmissivity is noted by Tr_0 , whereas the transmissivities in the presence of field are noted by Tr_{\perp} and Tr_{\parallel} for the ordinary and extraordinary rays, respectively. For the ordinary incident rays the electric displacement vector is perpendicular to the magnetic field, while for extraordinary rays they are parallel. From the storied data we have calculated the normalized transmissivities \overline{Tr}_{\perp} and $\overline{Tr}_{\parallel}$ defined as the ratios of the corresponding transmissivities in the presence of magnetic field to the transmissivity in absence of magnetic field. These quantities have finally been obtained as time functions for the periods following the sudden coupling or decoupling of the magnetic field.

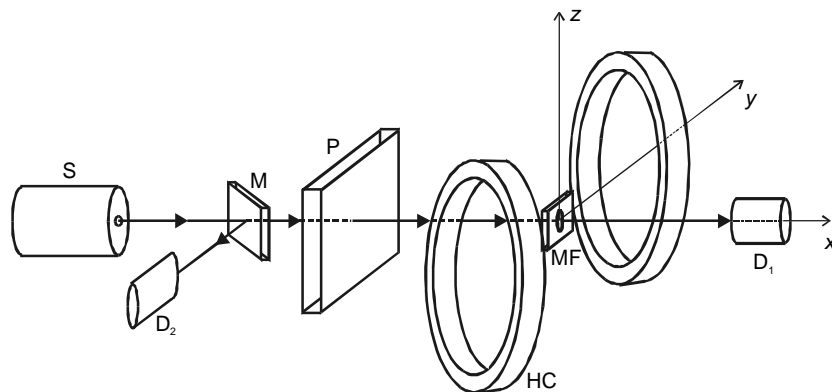

Fig. 1. The experimental setup for the study of transmissivity of a magnetic fluid thin film.

To observe the magnetochromatic effect a parallel beam of white light was brought in normal incidence to the magnetic fluid film. As the scattered light was transmitted through the magnetic film, it was directly exposed onto a color photo film, placed above the upper coil. A manual shutter was used to control exposure time.

3. Results and discussion

a) Optical microscope observations

When the magnetic fluid thin film was subjected to the external magnetic field parallel to its plane, we observed that the particle in the film start to agglomerate forming short chains along the

field direction. With keeping increasing magnetic field intensity, the short chains started to become larger discrete chains of about $10\ \mu\text{m}$. The first chains are named primary clusters and the later secondary clusters. When the field intensity is exceeding a critical value H_c , in the fluid film was formed a periodic long-chain structure, these formations being named macroclusters. For the magnetic fluid studied by us, this critical value was about $12\ \text{kA/m}$.

We have observed optically the long-chain periodic patterns formed inside the film subjected to a parallel magnetic field exceeding the critical value H_c , under different magnetic field intensities at constant sweep rate and under different sweep rates at fixed field strength. It was clearly observed that the distance between the macrocluster d measured from one side of one to the same side of neighboring and the macrocluster width a are inversely proportional to the magnetic field strength and the field sweep rate. These results were plotted as a function of the field strength, as shown in Fig. 2. It indicates that the ratio between the area of liquid phase and of macrocluster phase depends on the sweep rate for a periodic long-chain structure. Furthermore, the refraction indices of the liquid phase and of the macrocluster phase are different. Consequently, the level of anisotropy would be affected by the structure pattern formed in the film. To study their correlation, the ratio $a/(d-a)$ was also plotted as a function of magnetic field strength in Fig. 2. These curves demonstrate that they are also sweep rate dependent, their values reaching a saturation at relatively low field strength with a higher sweep rate. Moreover, these curves saturate at a relatively higher value for a higher sweep rate than that for a lower sweep rate.

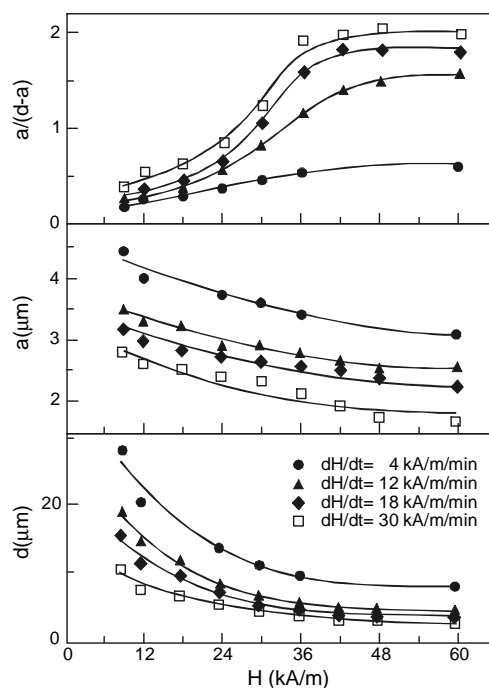

Fig. 2. Plot of the distance between long chains d , the chain width a , and of the ratio $a/(d-a)$ as functions of field strength at different sweep rate.

When the magnetic fluid thin film was subjected to an increasing perpendicular magnetic field, initial we observed the formation of disorder quantum columns. At a critical field strength H_h , an equilibrium two-dimensional hexagonal structure forms with particle columns occupying lattice vortices. If the field strength is increased to another critical value H_l , the pattern changes from a hexagonal structure to a labyrinthine pattern. In the $H_h - H_l$ range of the field strengths, we determined the distance d between particle columns by using fast Fourier transformation. We observed that this distance is roughly proportional to the inverse of the field strength. We have examined also the pattern formation in a thin magnetic fluid film of $20\ \mu\text{m}$ thickness. We have

observed that the distance between the particle columns increases with the film thickness.

b) Transmittance in parallel fields

In what regards the transmittance of magnetic fluid films, we have studied firstly the dependence of reduced transmittivities on the applied field intensity. The results are presented in Fig. 3, where one can observe that both the ordinary and the extraordinary rays have been attenuated by the magnetic field. The decrease in transmittivity of ordinary rays shows that the dominant mechanism for their attenuation is the Rayleigh scattering on macroclusters. The saturation trend of transmittivities in moderate-intensity magnetic fields is in agreement with our optical microscopy observations presented before. However the smaller values of transmittivities for ordinary rays cannot be explained though by just considering the mechanisms of light absorption by the cluster through the imaginary part of the electric polarization and of light Rayleigh scattering of light by the clusters. It is possible that in the range of low intensity fields the imaginary part of magnetic polarization has a role, as considered by Taketomi et al. [9]. This factor could also explain the small increase tendency of the extraordinary ray transmittivity as a function of field intensity at small values of this.

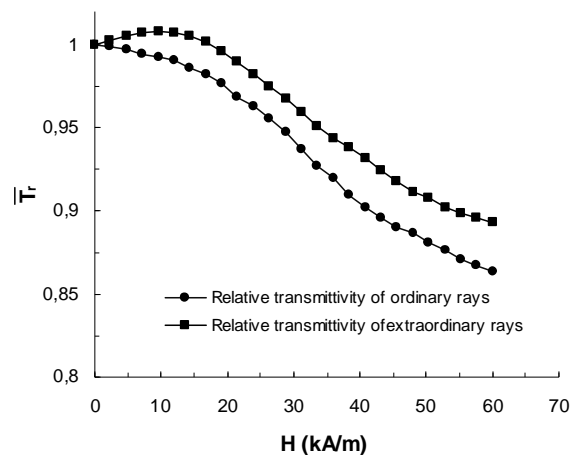

Fig. 3. The dependence of transmittivities of applied magnetic field strength.

Fig. 4 displays the time dependencies of ordinary and extraordinary rays transmittivities after abruptly applying or removing the magnetic field. One can see two evolution stages. During the first stage, right after the instantaneous application or removal of the field, the transmittivities change abruptly. The ordinary ray transmittivity has increased/decreased sharply during a time interval of the order of 10^{-1} s, the increment/decrement being larger for larger applied/cancelled field intensities. The amplitudes of the abrupt changes have been larger with about 50% for the field removal. The transmittivity of extraordinary rays has increased rapidly during a time interval of the order of 10^0 s, the increase being larger for larger applied field intensities. For field removals, the transmittivities of the extraordinary rays increased rapidly within a time interval of 10^0 - 10^1 s.

In the second stage the transmittivities change gradually in time and saturate at a constant value or at the initial value characteristic to the absence of the magnetic field. When a weak magnetic field was applied ($H < 150$ Oe), the transmittivity of ordinary rays remained constant during this stage, while the transmittivity of extraordinary rays has a small decrease. In the case of a magnetic field with a larger intensity ($H > 150$ Oe), during this second stage the transmittivity of ordinary rays continued to decrease slowly, within a time interval of 10^2 - 10^3 s, toward a constant value; the larger the intensity of the applied field, the smaller this constant value. After the removal of the magnetic field $H > 150$ Oe, the transmittivity of extraordinary rays increased until it reaching the initial value, within a time interval of 10^1 - 10^2 s.

From the comparison of time evolutions of transmittivities for the two kind of rays, it is observed that in the case of ordinary rays the variation is continuous in time, while in the case of extraordinary rays the variation has permanent small fluctuations around the average values

corresponding to each moment .

The two distinct stages in the time evolution of transmittivities, with an initial, abrupt, change followed by a slow variation, proves again the existence of at least two mechanisms of damping, one involving electromagnetic absorption and the other involving the scattering. The second stage shows clearly the successive transitions from primary to secondary clusters and then to macro-clusters after applying a magnetic field on one hand, and on the other hand the direct transition from macro-clusters to primary micro-clusters after the removal of the magnetic field.

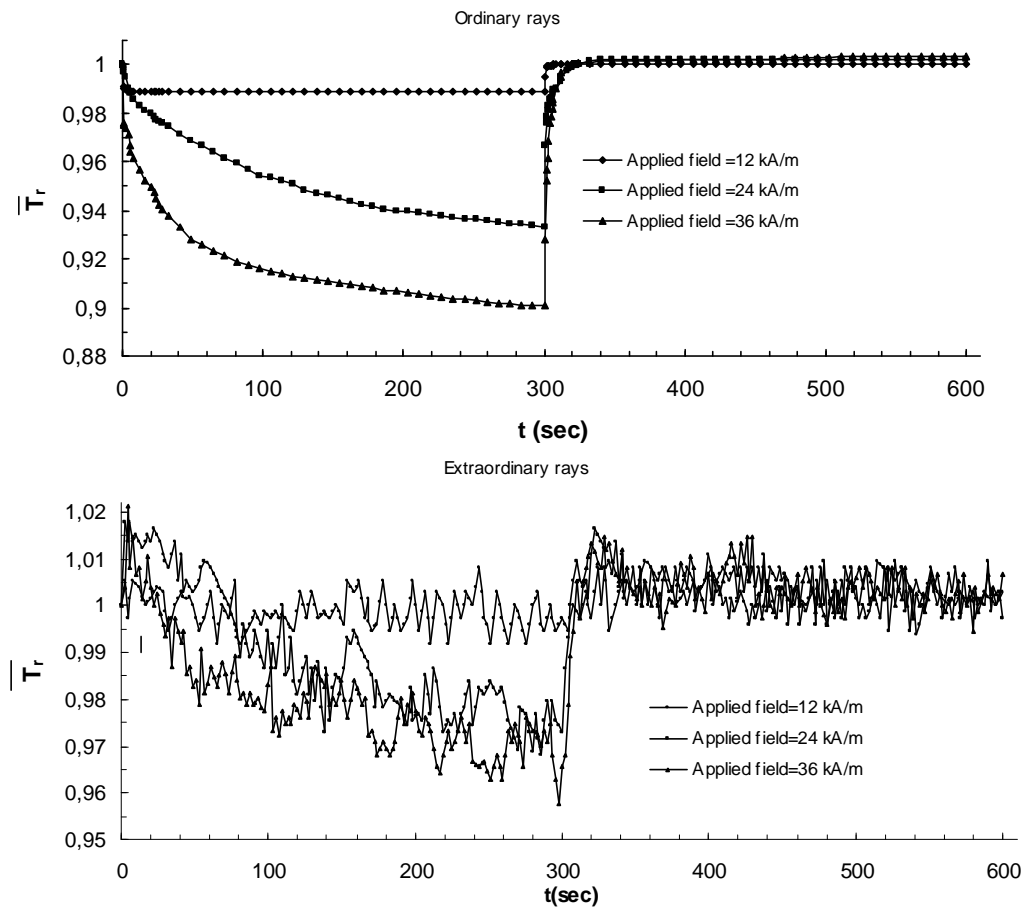

Fig. 4. The time dependencies of ordinary and extraordinary rays transmittivities after abruptly applying or removing the magnetic field.

c) Magneto-chromatic effect

If the distance d between particle columns of the ordered structure under perpendicular field is adjusted to several micrometers, the hexagonal structure acts as a two-dimensional optical grating which is capable of diffracting an incoming visible light [10,11]. Diffraction phenomena occur when a parallel light beam is incident normal to the film, and the constructive or the destructive interference occurs as the light way passes through the film. We have observed a chromatic ring resulted from the passage of a white light through the hexagonal structure with long-range grain boundaries. The central area is the zero order principal maximum of the diffraction pattern. Since the incoming white light consist of a mixture of all visible lights, a bright white spot appears at the center. In the first order principal maximum of diffraction pattern, the incoming white light is dispersed. The spatial distribution of colors depends on the wavelength of the light; read appears on

the outermost ring, and, successively, orange, yellow, green, blue, and violet. This phenomenon can be well explained by the grating equation $d \sin \theta = k\lambda$, where d is the column distance, θ is the angle between the outgoing color light beam and the normal to the film which is the vertical in the set-up, λ is the wavelength of the light, and $k = 1, 2, 3 \dots$. By giving a fixed d , a larger wavelength leads to a larger θ and also a bigger circular ring as $k = 1$.

4. Conclusions

For the magnetic fluid studied in this work, the time dependence of transmittivities is in agreement with optical microscopy observations of the time evolution of the structure and geometry of aggregates after the abrupt application or removal of magnetic field applied parallel to film. The two distinct stages in the time evolution of transmittivities, with an initial, abrupt, change followed by a slow variation, prove again the existence of at least two mechanisms of damping, one involving electromagnetic absorption and the other involving the scattering. The second stage shows clearly the successive transitions from primary to secondary clusters and then to macro-clusters after applying a magnetic field on one hand, and on the other hand the direct transition from macro-clusters to primary micro-clusters after the removal of the magnetic field.

The distance between the columns of hexagonal structures in magnetic fluid films under perpendicular fields can be adjusted by changing the control parameters, such as the magnetic field strength, the sweep rate, the thickness of the film, and the volume fraction of solid magnetic phase in magnetic fluid. We found that the chromatic ring expanded upon increasing the field strength. This result is attributed to the decrease in the distance between columns for higher field strength.

References

- [1] C. F. Hayes, *J. Colloid Interface Sci.* **52**, 239 (1975).
- [2] N. A. Yusuf, *J. Phys. D* **22**, 1916 (1989).
- [3] H. Wang, Y. Zhu, C. Boyd, W. Luo, A. Cebers, R. E. Rosensweig, *Phys. Rev. Lett.* **72**, 1929 (1994).
- [4] C. Y. Hong, H. E. Horng, I. J. Jang, C. J. Hsu, Y. D. Yao, H. C. Yang, *J. Appl. Phys.* **81**, 4275 (1997).
- [5] S. Taketomi, S. Ogawa, H. Miyajima, S. Chikazumi, *IEEE Transl. J. Magn. Jap.* **4**, 384 (1989).
- [6] J. E. Martin, K. M. Hill, C. P. Tigges, *Phys. Rev. E* **59**, 5676 (1999).
- [7] H. E. Horng, C. Y. Hong, S. L. Lee, C. H. Ho, H. C. Yang, *J. Appl. Phys.* **88**, 5904 (2000).
- [8] V. Socoliuc, D. Bica, *Progr. Colloid. Polym. Sci.* **117**, 131 (2001).
- [9] S. Taketomi, M. Ukita, M. Mizukami, H. Miyajima, S. Chikazumi, *J. Phys. Soc. Jap.* **56**, 3362 (1987).
- [10] H. E. Horng, C. Y. Hong, W. B. Yeung, H. C. Yang, *Appl. Optics* **37**, 2674 (1998).
- [11] H. E. Horng, C. Y. Hong, S. Y. Yang, H. C. Yang, *J. Phys. Chem. Solids* **62**, 1749 (2001).