

## GMI TORQUE SENSOR MODULE WITH FM TRANSMITTER

T. Uchiyama, T. Meydan\*

Wolfson Centre for Magnetics Technology, School of Engineering, Cardiff University,  
P.O. Box 925, Cardiff, CF24 0YF, UK

The Giant Magneto-Impedance (GMI) torque transducer module with frequency modulation (FM) transmitter is proposed for the first time to detect the torque from a rotating shaft. The proposed transducer module has advantages such as simple construction without the torsion bar, high accuracy, low power consumption and an easy installation. The operation of FM transmitters, which is based on Complementary metal Oxide semiconductor (CMOS) inverters, is analyzed. The proposed circuit design allows the module to be fabricated in a single Integrated Circuit (IC). Basic experiments for signal transmission were carried out. The linear frequency modulation with the applied torque is achieved in the torque range of  $\pm 5$  Nm for a 13 mm diameter brass shaft.

(Received April 26, 2004; accepted June 3, 2004)

*Keywords:* GMI, Torque transducer, FM transmitter

### 1. Introduction

Low cost, accurate and reliable torque sensors are required in industrial applications, especially in the automotive industries. Table 1 shows basic features based on torque sensing methods. The most common method used for measuring torque is strain gauge torque transducers, which have advantages such as high accuracy and small size. The contact bridge technique can reduce common mode noise effectively. The second most common method used is the twist angle type transducer, which has advantages such as high accuracy and contact-free construction. Generally, both methods require a sensing segment (torsion bar), which is slightly narrower than the shaft, subjected to the torque. Introducing a torsion bar system results in losing the stiffness of the mechanical assembly.

Table 1. Basic features of torque sensing methods.

	Accuracy	Size	Simplicity	Contact free	Frequently used
Strain gauge	Good	Suitable for system integration	Complicated structure due to a torsion bar	Possible (power supply and signal transmission are required)	Most
Twist angle	Good	Long shaft is necessary	Complicated structure due to a torsion bar	Basically non-contact	Second
Conventional magnetostriction	Less than above	Only short shaft is required	Simple	Basically non-contact	

It is difficult to use a torsion bar type transducer as a built-in sensor for controlling the generated torque. In addition, such a complicated sensing system leads to high costs.

\* Corresponding author: meydan@cf.ac.uk

On the other hand, conventional magnetostrictive type torque transducers have been investigated as a non-contact technique. Three main types have been reported: cross type [1], coaxial type [2-4] and polarized ring type [6]. The cross type with magnetic heads has some problems if it is mounted directly onto the shaft [1]. The magnetic properties of the shaft usually are not good enough for accurate torque detection. Amorphous materials attached to shafts have been mainly used for the coaxial type [2-4]. Amorphous materials have a large magneto-mechanical coupling factor so that a high sensitivity for the torque detection has been obtained [2-4]. Furthermore, the dynamic torque has been detected by using the coaxial type [2]. The main problem arises from the contact between the amorphous material and the shaft. Introducing inhomogeneous stress by gluing increases the hysteresis effect [4]. The polarized magnetic ring type is one of the simplest torque transducer [5]. Both signal transmission and external excitation are not necessary, while a special technique is required for the attachment of the magnetic ring on the shaft. This transducer can have some problems in accuracy because of a mechanical hysteresis due to a stress transfer from the shaft to the magnetic ring [5].

Recently, a new sensitive impedance strain gauge, which is based on magnetostrictive amorphous wires, has been investigated [6,7]. The giant magneto-impedance (GMI) strain gauges have a large gauge factor of 2000. The high sensitivity makes it possible to detect the shaft torque without using a torsion bar. The local attachment of the wire on the shaft is achieved because of the excellent mechanical properties of amorphous materials. This technique is effective for avoiding the problems due to gluing. However, a signal transmission is needed to detect the torque from a rotary shaft. The GMI torque sensor module with a FM signal transmitter based on CMOS inverters is proposed for the first time in this paper.

## 2. GMI strain gauge

$\text{Co}_{68.15}\text{Fe}_{4.35}\text{Si}_{12.5}\text{B}_{15}$  amorphous glass-covered wires 5 mm in length and 20  $\mu\text{m}$  in diameter have been used in this investigation. The glass has been removed and the wires have been annealed by passing 40 mA dc current for 20 minutes by using techniques previously published[8]. The gauge factor of the wire is more than 2000 [7] while the wire has small negative magnetostriction  $\lambda_s$ . When the skin effect is induced by the high frequency current, which is flowing through the wire, the wire impedance is expressed as

$$|Z| = (a / 2\sqrt{\rho}) R_{dc} \sqrt{\omega \mu_{\theta}(\sigma)} \quad \text{for } \delta \ll a, \quad (1)$$

where  $a$  is the radius of the wire,  $\delta$  is the skin depth, and  $\rho$  is the resistivity,  $R_{dc}$  is the dc resistance,  $\omega$  is the angular frequency,  $\mu_{\theta}$  is the circumferential permeability, and  $\sigma$  is the applied stress to the wire. According to eq. (1) the change in  $\mu_{\theta}$  with stress results in the change of the impedance of the amorphous wire. A high permeability and a strong magnetomechanical coupling are required for a high sensitive strain gauge. Generally the highest permeability is obtained in materials having low  $|\lambda_s|$ . The magnetomechanical coupling factor,  $K_{33}$ , which is given by equation (2), is the figure of merit [1].

$$K_{33} = W_{\sigma} / (W_H + W_{\sigma} + W_K + W_U + W_N), \quad (2)$$

where  $W_H$  is the magnetic field energy,  $W_{\sigma}$  is the elastic stress energy,  $W_K$  is the crystalline energy,  $W_U$  is the uniaxial anisotropy and  $W_N$  is the shape anisotropy energy. A very thin soft magnetic amorphous wire is required with  $W_K$ ,  $W_U$  and  $W_N \equiv 0$ . In this case  $K_{33}$  approaches unity even for a small  $|\lambda_s|$ . Furthermore, in order to have a uniform anisotropy, low magnetostrictive Co-rich amorphous wires are preferred [9].

## 3. Transducer design

A sensor circuit for exciting MI elements has been developed utilizing a CMOS multi vibrator

[10]. Fig. 1 shows the circuit diagram of the module and the torque measuring system. The circuit is composed of only two analog amplifiers and four CMOS inverter gates. One of the analog amplifiers is used for signal amplification and the other is used for the control of the oscillation frequency,  $f_{osc}$ , of a FM transmitter. The FM transmitter is composed of two inverter gates and RC component for the pulse generation. The oscillation frequency,  $f_{osc}$ , is proportional to the output voltage of the analog amplifier. The pulse train current having a frequency of  $f_{osc}$  and a width of about  $0.3 \mu s$  is applied to the amorphous wires using the other two inverters. The skin effect due to the applied pulse current leads to GMI effect in the wire. The CoFeSiB amorphous wires are attached on the 13 mm diameter brass shaft aligning the wire axis in the direction of 45 degrees, which corresponds to the main direction of an induced strain due to the applied torque. The ends of the wires having  $20 \mu m$  in diameter are bonded on the pads glued on the shaft surface as shown in Fig. 2.

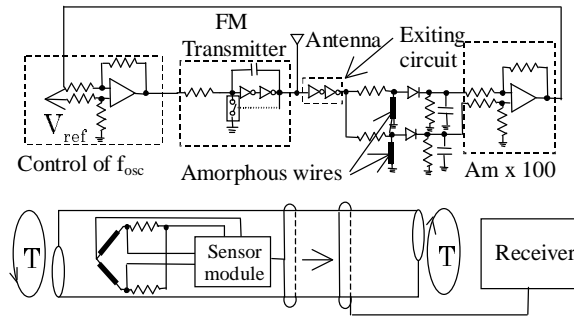

Fig. 1. GMI torque sensor module with FM transmitter.

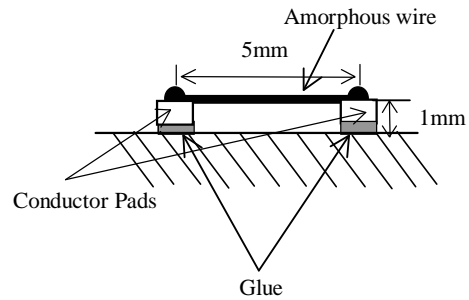

Fig. 2. Attachment technique of the wire gauge on the shaft surface.

The local attachment technique is effective for avoiding the problems due to gluing the entire wire. The induced strain,  $\epsilon$ , due to the applied torque,  $T$ , is given by  $\epsilon = 16T(1+\nu)/(\pi ED^3)$ , where  $\nu$  is the Poisson's ratio,  $E$  is the Young's Modulus, and  $D$  is the shaft diameter. The impedance is proportional to the torque so that  $f_{osc}$  is proportional to the torque as well. The design allows the module to be fabricated in a single IC. The sensor module was placed on the shaft. The signal is transmitted along the shaft axis so that a high signal to noise ratio can be obtained.

#### 4. Operation of FM circuit

Fig. 3a illustrates an external connection of the FM transmitter circuit and Fig. 3b illustrates the voltage waveforms in the circuit. The circuit is a voltage controlled oscillator based on inverter gates in combination with an analogue switch. Assume no electrical charge in the condenser  $C$  at  $t = 0$ . The voltage  $V_1$  increases with increasing time  $t$  as  $C$  is being charged, if a dc input voltage  $V_{in}$  is being applied. Once the voltage  $V_1$  reaches the threshold value  $V_T$ , the output voltage of the inverter 1 is digital low. At the same time, the output of the following inverter is high and it turns the analogue switch on. The time interval  $T_1$  is a function of both time constant  $RC$  and the input voltage  $V_{in}$ . Finally, both  $V_1$  and  $V_2$  return to 0 due to a discharge of  $C$ . The pulse width  $\tau$  corresponds to the discharge time of  $C$ .  $f_{osc}$  is inversely proportional to  $T_1 + \tau$  so that  $f_{osc}$  is given by the equation:

$$f_{osc} = \frac{1}{\tau + RC \ln \left[ \frac{V_{in}}{V_{in} - V_T} \right]} \quad (3)$$

Fig. 4 shows  $f_{osc}$  versus  $V_{in}$  characteristics of the FM transmitter.  $f_{osc}$  can be controlled linearly by voltage in the range of  $V_{in}$  from 4V to 8V. The circuit having few gates realizes small power consumption. The total power consumption of the CMOS inverter circuit (FM and exciting circuit) is less than 10 mW.

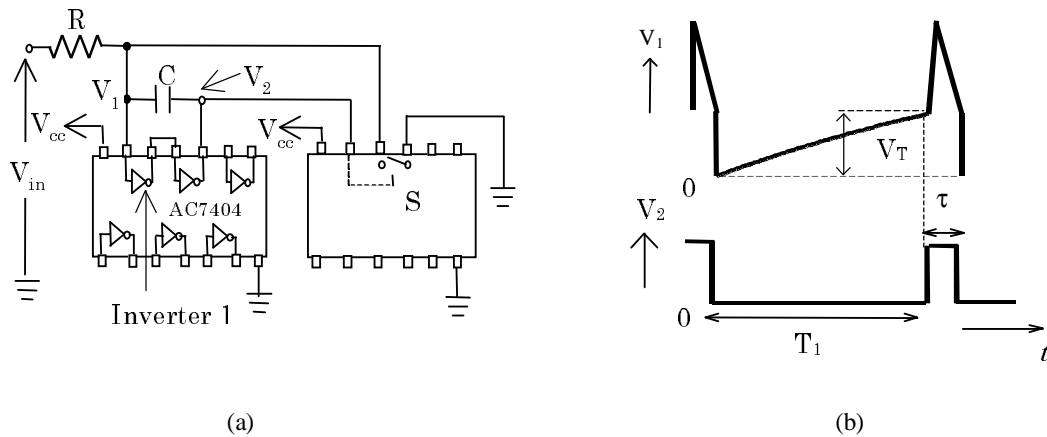

Fig. 3. FM circuit: a) external connections, b) voltage waveforms.

Basic signal transmission experiments are performed using the proposed FM transmitter. Both transmitting antenna and receiving antenna were wound around the shaft as shown in Fig. 5a.

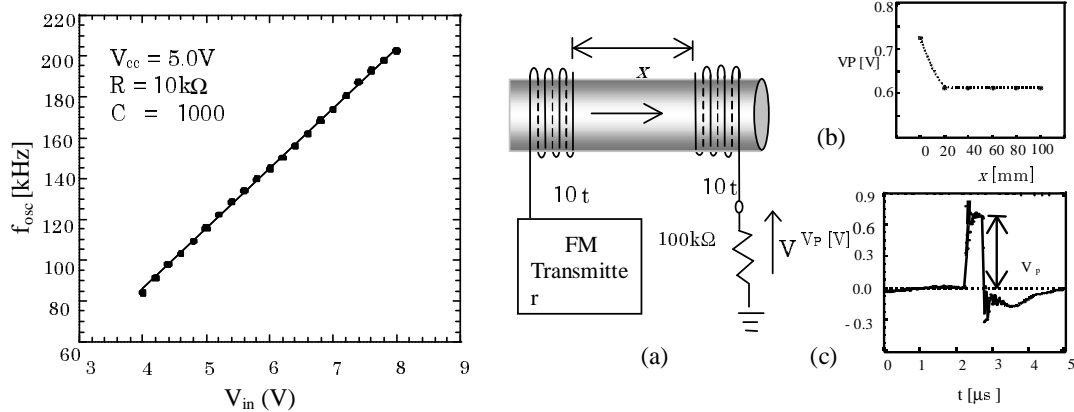

Fig. 4.  $f_{osc}$  versus  $V_{in}$  characteristics of FM transmitter.

Fig. 5. Signal transmission experiment: a) placement of transmitting and receiving antennas, b) voltage waveform at a receiver side, c)  $V_p$  versus  $x$  characteristics.

Fig. 5b illustrates the voltage waveform at the receiver side. The peak value  $V_p$  of the voltage is 0.7 V, which is large enough for an accurate signal processing. Fig. 5c shows  $V_p$  dependence on the transmission distance  $x$ .  $V_p$  is almost constant for a long distance along the shaft axis (Fig. 5c). Although  $f_{osc}$  is not so high, the pulse voltage contains high frequency components up to 100 MHz. The high frequency signal components can easily be detected away from the shaft, hence making it a non-contact transducer.

## 5. Torque detection characteristics

Fig. 6 shows the response of the sensor module in torque detection. A dc magnetic field  $H_{ex}$  of 200 A/m is applied parallel to the shaft axis. Therefore, the bias field  $H_b$  along the wire axis is about 140 A/m. A linear relationship between  $f_{osc}$  and the torque is obtained in the torque range of  $\pm 5$  Nm with a small mechanical hysteresis. The influence of a magnetic field on the torque detection characteristics is investigated.

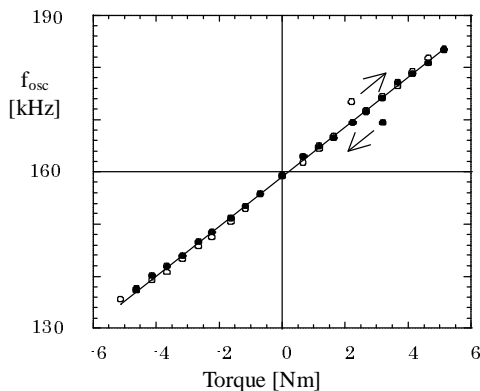

Fig. 6.  $f_{osc}$  versus torque characteristics for the sensor module.

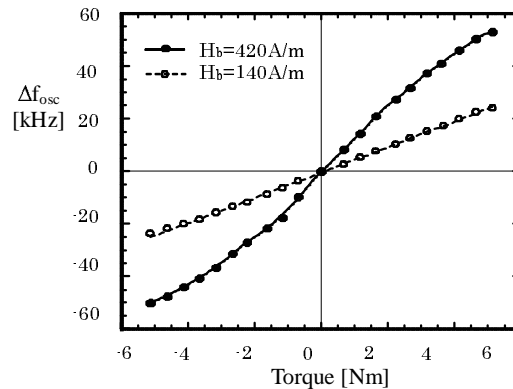

Fig. 7.  $f_{osc}$  versus torque characteristics with parameter of  $H_{ex}$ .

Fig. 7 shows  $\Delta f_{osc}$  vs. torque characteristics of the GMI torque sensor module.  $\Delta f_{osc}$  is defined as  $f_{osc}(\epsilon) - f_{osc}(\epsilon=0)$ . An improved change in  $\Delta f_{osc}$  at the expense of nonlinearity is obtained for the case of  $H_b = 420$  A/m ( $H_{ex} = 600$  A/m). The sensitivity reduces when a bias field  $H_b$  higher than 420 A/m is applied. The critical bias field, at which the sensitivity reaches to a maximum, almost corresponds to the value of the anisotropy field  $H_k$  for the dc current annealed amorphous wire [11]. The hard axis field for a domain wall decreases the domain wall energy and thus the coercivity [12]. The bias field  $H_b$  acts as a hard axis field. Improving soft magnetic properties seems to result in an improvement in sensitivity.

## 6. Conclusions

GMI torque transducer module with a FM transmitter is proposed for the first time. The module is designed to detect torque from a rotary shaft on which a GMI sensor having a high gauge factor is attached. The FM circuit is a pulse frequency modulation type based on the CMOS inverter. The circuit having few inverter gates realizes small power consumption. The linear frequency modulation with the applied torque is achieved with a small mechanical hysteresis.

## References

- [1] R. Boll, K. J. Overshott, *Magnetic Sensors*, VHC, Weinheim, 1989, pp. 106.
- [2] K. Harada, I. Sasada, T. Kawajiri, M. Inoue, *IEEE Trans. Magn.* **18**, 1767 (1982).
- [3] I. Sasada, A Hiroike, K. Harada, *IEEE Trans. Magn.* **20**, 951 (1984).
- [4] M. Hardcastle, T. Meydan, *Sensors Actuat.* **A81**, 121 (2000).
- [5] L. J. Garshelis, *IEEE Trans. Magn.* **28**, 2202 (1992).
- [6] L. P. Shen, T. Uchiyama, K. Mohri, E. Kita, K. Bushida, *IEEE Trans. Magn.* **33**, 3355 (1997).
- [7] T. Uchiyama, T. Meydan, *J. Optoelectron. Adv. Mater.* **4**, 277 (2002).

- [8] H. Chiriac, T. A. Ovari, C.S. Marinescu, *IEEE Trans. Magn.* **33**, 3352 (1997).
- [9] M. Sahashi, T. Kobayashi, T. Domon, K. Inomata, *IEEE Trans. Magn.* **23**, 2194 (1987).
- [10] T. Kanno, K. Mohri, T. Yagi, T. Uchiyama, L. P. Shen, *IEEE Trans. Magn.* **22**, 3358 (1997).
- [11] V. A. Zhukova, A. B. Chizhik, J. Gonzales, D. P. Makhnovskiy, L. V. Panina, D. J. Mapps, A. P. Zhukov, *International Workshop on Magnetic Wires, San Sebastian, Spain, 2001.*
- [12] L. V. Panina, H. Katoh, K. Mohri, *IEEE Trans. Magn.* **29**, 2524 (1993).