

Experimental research about characterization of novel porous composites with special applications

P. A. POP^{a*}, D. LUCA-MOTOC^b

^aUniversity of Oradea, Department of Mechatronics, 1 Universitatii Str., 410087, Oradea, Romania

^bTransilvania University of Brasov, Department of Materials Science, 29 Eroilor Blvd, 500036, Brasov, Romania

Porous materials are usually applied in buildings industry such as concrete, plasters, or in special applications as isolators of buildings, sonic barriers along the freeways to suppress the noise pollutions. The paper presents an experimental research used for determination of main characteristics of porous composites from gypsum family with special applications, like these thermal and acoustical panels, bandages and lightweight orthopedic corsets. The samples from gypsum and special acoustic-gypsum with original receipts were been subjected at multiple tests by used modern dynamic installations to determine their elastic characteristics. These new composite materials obtained from modeling gypsum plaster reinforced with expandable polystyrene waste, or perlite, glass fibers, etc., which improved their sound absorption and thermal properties. The quality characteristics of gypsum family with special applications depend on many factors, such as fabrication process, granulation process, roast temperature, work temperature, environment, additive use, breakage, etc. In this way, a new fabrication process of gypsum plaster by heating in a microwave field of clean breakage gypsum was used to obtain the novel composites, which due to a great productivity, machining efficiency and high quality of materials. The results of experiments confirmed the methods and installations used, which can be carrying on other sonic-materials.

(Received April 9, 2015; accepted June 24, 2015)

Keywords: Elastic characteristics, Gypsum plaster, Microwave energy, Porous material

1. Introduction

Porous composites have known lately a large and continuous development in many important sectors of economy, such as industry, buildings, environment and medicine.

Many composites are designed to retain porosity that has poured structure specific usefulness, which can include the capabilities of mass transfer and liquid retention, lighter weight, enhance opacity and gloss, controlled spread, imbibition and head conduction.

Porosity represents a desired property when weight, optical and flux properties are of primary interest.

However, the presence of porosity in composites may know down the material characteristics affecting their performance in service that can be compensated by applying an adequate designing, manufacturing and engineering particulate-polymer composites with porosity [1-10].

The tendency of introducing the green city's buildings and increasingly suppressing of noise pollution represents a priority for the majority of world leaderships and material manufacturers.

This problem can be resolved by applying multiple solutions, such as using a proper management of noise control and material with acoustic properties, which due to enhance the indoor/outdoor environmental quality [11-15].

The thin, lightweight and low-cost materials that will absorb sound waves in wider frequency regions are desired. In this sense, polymers and composite materials have more used for absorption of sound and reduction of noise.

The attenuations into particle layers are promoted by two main processes and explain the high-absorption in smaller gypsum plaster with addition of cellulose fibers, mineral wad and cardboard, known as re-gyps, de-gyps improves the sonic and thermal insulation of rooms.

The fabrication process of gypsum from natural gypsum involves crushing and grinding the gypsum mineral that is heating at 150°C [15, 20-23].

The main reaction to obtain the gypsum plaster is dehydration or water elimination from the structure.

The calcium sulfate hemihydrate ($\text{CaSO}_4 \cdot 1/2\text{H}_2\text{O}$) formation takes place at a temperature of 95-120°C, according to chemical reaction:

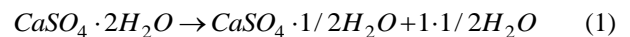

If the temperature raising above 300°C until 700°C the dehydration process going on resulting an anhydrous:



Consequence of these reactions, the stable gypsum was transformed into an unstable product (hemihydrate gypsum plaster or anhydrous), which has always the tendency to back in a hydrated stable state.

At treatment of hemihydrate at the temperature of 1200-1400°C, the death gypsum plaster is obtained.

The main properties of materials from gypsum family are lightweight, acoustic and thermal insulation, fire resistance, regulation of hygrometry, etc.

The paper has the goal to present an experiment for determination the main characteristics of porous composites from gypsum family with special applications like these thermal and acoustical panels, bandages and lightweight orthopedic corsets.

The samples from gypsum and special acoustic-gypsum with original receipts were been subjected at multiple tests by used modern dynamic installations to determine their elastic characteristics. These new composite materials are in conformity with UE norm, obtained from modeling gypsum plaster reinforced with expandable polystyrene waste, or perlite, glass fibers, etc. In addition, a new fabrication process of gypsum plaster by heating in a microwave field of clean breakage gypsum has used to obtain the novel composites.

2. Experiment

2.1. Theory (theoretical fundamental)

Besides the gypsum plaster is a hydraulic aerial binder material that by treats with water results slurry, reinforcing by setting becomes a dielectric with losses [24, 25]. After the gypsum plaster is getting in water, until at properly setting, three phases are distinguished:

- Dissolving of hemihydrates in water, when occurs self-hydration;
- Saturation solution in hemihydrates and its oversaturation in dehydrate;

Separation of small-dehydrate particles that is surrounding with water.

After these phases, the fine dehydrated crystals are aggregate formed a rigid mass, without plasticity. The passing from plastic state (slurry) in a rigid state indicates the initial setting (incorporation of 1·1/2 water molecules), representing the moment of stiffen mixture, named the end setting. Reverse, by heating of gypsum is a loss of 1·1/2 water molecules resulting gypsum plaster. Starting from the fact that hydrated gypsum plaster is a dielectric with losses more used in electronic under form of isolator plates, and its similitude with gypsum ore, occurs the possibility to heat the gypsum ore by microwave energy [24, 25].

The microwaves are strongly interacting with dielectric materials, due to water elimination from the compositions [26, 27]. The fundamental physical relations of gypsum available at heating of a dielectric with losin a microwave field refer to dielectric losses occurring in a process of water polarization inside of electromagnetic field. The dielectric losses lead to absorption of caloric energy and water loss by evaporation. In that situation, the electric induction- D is getting by [24, 25]:

$$D = E + 4\pi \cdot P \quad (3)$$

where: E -is alternating electric field, which varies after the law $E = E_0 \exp(i\omega t)$, and P - total water polarization. The power of lost energy getting into the heat, in volume unit is [24, 25]:

$$Q_0 = E \cdot J \quad (4)$$

where $J = dP/dt$ – is current density of displacement in dielectric; which it can be expressed and by [24, 25]:

$$Q_0 = \frac{\varepsilon \cdot E_0^2 \cdot \omega}{8\pi} \tan \sigma \quad (5)$$

where: E_0 -is variable electric field, ε - real dielectric constant, ω - high frequency of electric field, and δ - angle of lost. Analyzing (4) and (5), it results that in a dielectric with losses, a variable electric field dissipates a thermal energy- Q_0 .

To obtain a greater dissipated energy a more intense electric field application is required.

The dissipated power can be also improving by raising the frequency, which is easy to realize by microwaves.

The microwave generators with high-power are large applied in heating industrial technique by using high-frequency generators with high-power magnetrons. Their advantages are that have a simple construction and low costs [26-28].

The dissipated energy in a microwave range for gypsum involves in research and heating testing can be a resonant cavity of the microwave oven.

This cavity used for heating of dielectrics has a parallelepiped shape with dimensions large compared to the wavelength used.

The chatter frequency of resonant parallelepiped cavity is expressing by the relation [24, 25]:

$$f = c \left[\left(\frac{l}{2a} \right)^2 + \left(\frac{m}{2b} \right)^2 + \left(\frac{n}{2d} \right)^2 \right]^{1/2} \quad (6)$$

where: c -is light speed, a, b, d -cavity sizes, and l, m, n -whole numbers.

The distribution of electric field- (E) and magnetic field- (H) in a parallelepiped cavity of the microwave oven is showing in details, in Fig.1.

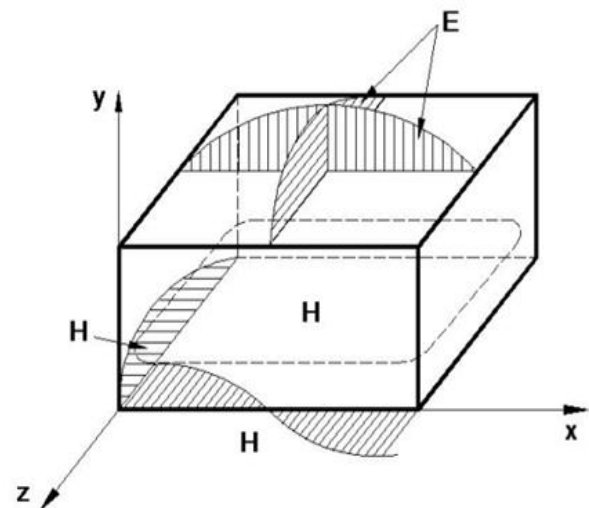

Fig. 1. Distribution of electric field- (E) and magnetic field- (H) in parallelepiped cavity of microwave oven

2.2 Fabrication of gypsum with microwave energy

A proper fabrication process of gypsum involves using of microwave energy that based on its dielectric properties. The experiment of heating gypsum ore in lab tests condition used a microwave oven type Samsung GE82 with the following characteristics:

- Power supply = 220V AC, 50Hz,
- Power consumption = 1300W,
- Microwave output power = 100/850W,
- Microwave frequency = 2.45GHz,
- Magnetron OM75P,
- Outside dimension = 489(W) x 275(H) x 406.5(D) mm,
- Cavity dimension = 330(W) x 211(H) x 329(D) mm,
- Volume= 23 l, and net weight = 15kg.

For a uniform heating, inside of cavity is getting in the parts in moving, on which put dielectric probe of gypsum that has the grained of 5-20 mm and the weight of 200g.

The temperature inside of the oven was between of 200-300°C, which is rising in an extreme short time to assure dehydration of gypsum.

The dehydration time was during of 30 min in a rough vacuum. At the end of the cycle, it started a suction installation from enclosure. After dehydration, the gypsum plaster obtained has subjected to a stabilization heat treatment during a few days into an oven, following by a grinding and testing at hydration.

Fig. 2 presents a resonant cavity of the microwave oven, in which is doing the heat of gypsum ore, where is a rotation disk.

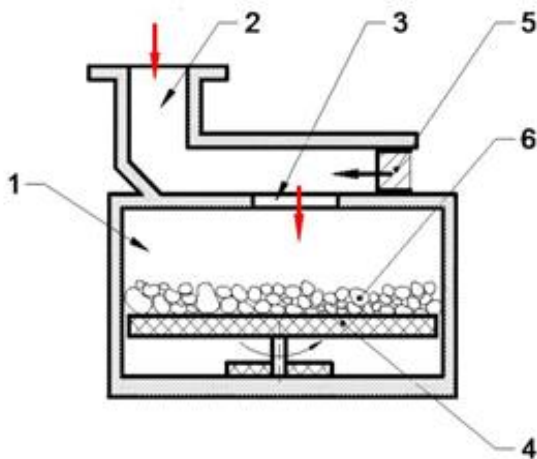

Fig. 2. Resonant cavity for heating of gypsum probes: 1 - is enclosure, 2-input of microwave energy, 3-couple of wave, 4-rotated panel, 5-power adjustment, 6-granules of gypsum ore.

Figs. 3-5 presented the microscopic structures of powder of gypsum plaster obtained in microwave range (plaster-*m*), comparative with structures of α -modeling plaster and β -construction plaster, with the magnitude of 500X.

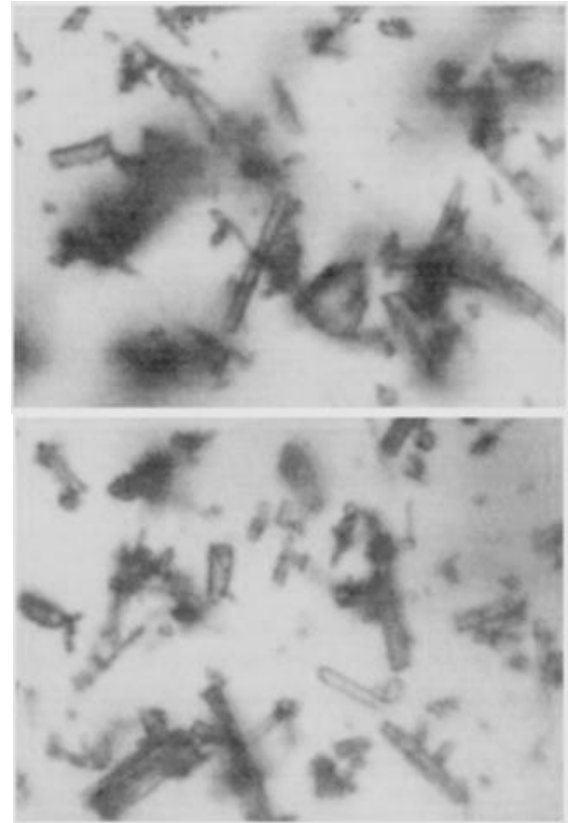

Fig. 3. Microscopic structures of α -gypsum plaster samples

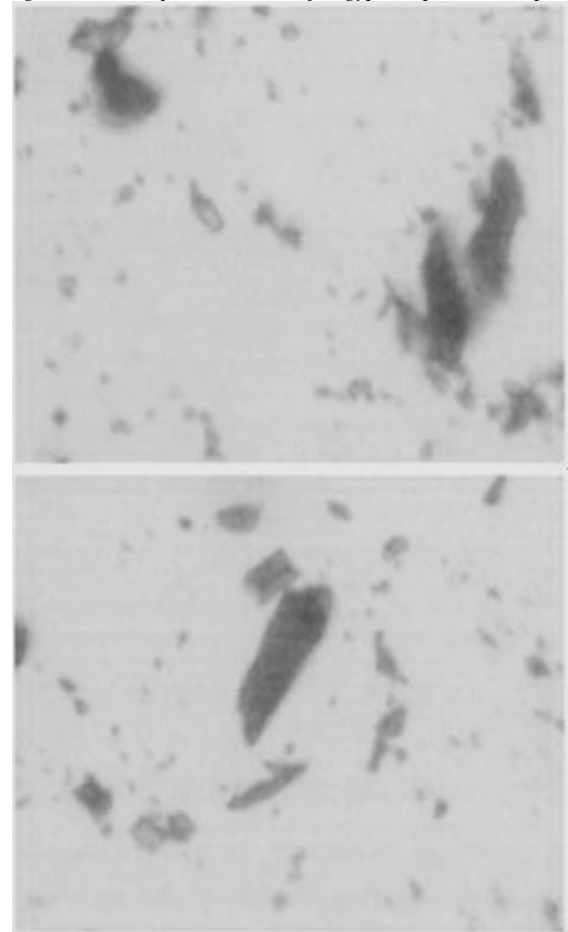

Fig. 4. Microscopic structures of β -construction gypsum plaster samples.

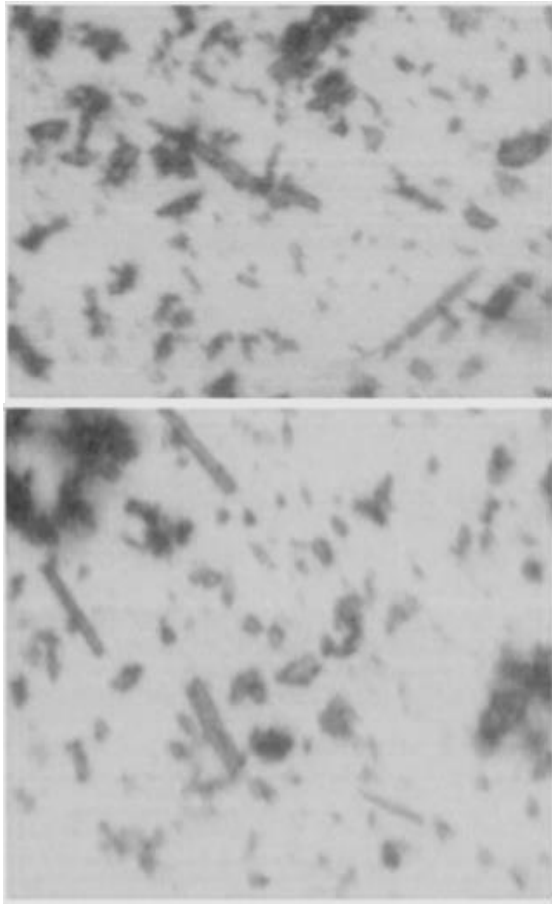

Fig. 5. Microscopic structures of m-plaster samples

2.3. Materials

The samples used for experiments present original receipts and were been manufactured in collaboration with “Congips” Co from Oradea.

Table 1: The physics-mechanic characteristics of gypsum family

Characteristics	Type of Samples			
	Acg	Abs	DAbs	Ort
Setting time				
-Start	8	11	11	8
-End	20	20	20	16
[min]				
Water of normal consistence [%]	48	70	70	116
Bending strength [MPa]	1.35	0.95	0.95	0.7
Compression strength [MPa]	4,45	2.4	2.4	2.75
Density [kg/m ³]	670	680	680	720

There are used four types of gypsum (Tab.1), such as:

- Special acoustic gypsum (Probe Acg)*, by adding 45% of modeling α -gypsum plaster, 5% of perlite and 2% of expandable polystyrene (ESP), used for acoustic panels.
- Acoustic α -modeling gypsum plaster I (Probe Abs)*, on the base of 93% of modeling α -gypsum plaster, 5% of perlite and 2% of expandable polystyrene (ESP), used for acoustic panels.
- Acoustic α -modeling gypsum plaster II (Probe DAbs)* is similar with *probe Abs*, only painted with dispersil to withstand the humidity for outside acoustic panels.
- Orthopedic α -modeling gypsum plaster (Probe Ort)*, on the base of α -plaster gypsum-85% and perlit-15%, used to fabrication of dressing and lightweight orthopedic corsets.

In addition, it was used the reinforced matrix of fiberglass with length of 30-35mm for enhancing the mechanical properties of gypsum materials.

2.4. Elastic characteristics of gypsum materials

One's main properties of gypsum family materials are the sonic and thermal properties, also the lightweight for medical applications, which involves knowing them elastic characteristics.

In general, certain characteristics of materials can be found in norms and standards, but less about of elastic modulus, Poisson's ratio, sonic-absorbent coefficient, etc. that can be determined individual for each type of material.

For determination the elasticity modulus - E and rigidity modulus - G of gypsum materials was used a special dynamic installation composed from a mechanical device to produce a vertical applied force on a gypsum sample and an electronic system to acquisition and interpretation of data, presented in Fig. 6 [29].

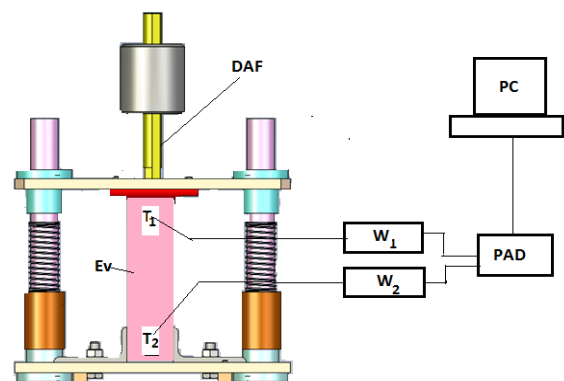

Fig. 6. Dynamic installation for determinations the elastic modulus of gypsum: DAF-is device of axial force application, Ev- gypsum sample, T_1, T_2 -strain gages, W_1, W_2 -electronic Wheatstone bridges, PAD-A/D board, and PC-computer.

The calculus of elastically modulus of gypsum is based on determination the longitudinal mechanical waves' velocity passing through the gypsum sample, subjected to a vertical concentrated shock.

In this case, a device of applied axial force (DAF) produces the vertical shock force that is getting in the gypsum sample (E_v). The sample has a cylindrical shape on which are fixed two strain gages (T_1 and T_2), at a predictable distance ($l = 470\text{mm}$).

Each strain gage is separately connected to one electronic Wheatstone bridge circuit (W_1 and W_2), type "Switch & Balance Unite SB-10 with digital Strain Indicator-P3500, which are linked to an A/D board (PAD) type NI USB6251, and then to a PC.

The strain gages allow the acquisition of time signal at start- t_1 and at end- t_2 , respectively, according to action of vertical force through a cylindrical sample.

Therefore, the time of impulse is $t = t_1 - t_2$ that assures determination of elastic waves velocity in the solid medium [30], with the formula:

$$c = \frac{l}{t} \quad (7)$$

The elasticity modulus of gypsum sample is getting with the formula:

$$E = c^2 \cdot \rho \quad (8)$$

Between the elasticity modulus- E and rigidity modulus- G exists the relation:

$$G = \frac{E}{2(1+\mu)} \quad (9)$$

For measuring the shock time of vertical applied force passing through gypsum cylinders was used MATLAB R12b Program by two original and special programs: "Dquest-2m" for data acquisition and "Evaluare-1.m" for calculus and plot the diagram of time.

The dynamic tests used for determination the elastic modulus of gypsum has made for two types of gypsum, casting under cylinder form with length of 500mm.

On the surface of the cylinder are mounted two strain gages at a predictable distance of 470mm between them.

For each type of gypsum test has made 10 measurements (5 measurement tests at each end of the cylinder) by applying a vertical force with DAF, obtained an average shock time passing through the cylinder gypsum.

For determination of sound absorption coefficients of gypsum has used an impedance tube type *AFD 1000-AcoustiTube* (Kundt's tube) according to DIN EN ISO 10534-2, with an inner diameter of 100mm and range frequency of 50-2000Hz. The measuring results allow a direct computation of rated sound absorption sample in front of an acoustic material according to DIN EN ISO 11654 [31].

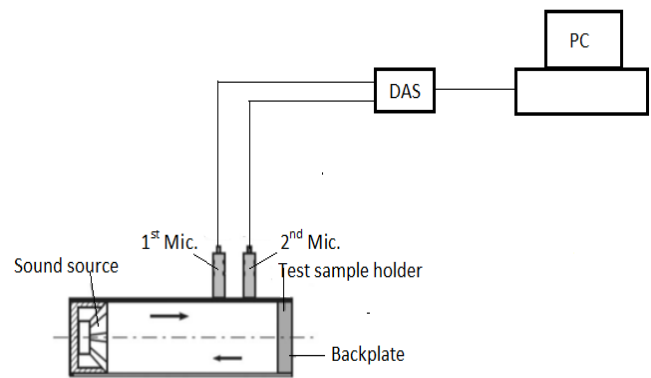

Fig. 7. Scheme of installation of impedance tube with two microphones transfer-function method that used for determination of sound absorption coefficient

Inside of the impedance tube is generated a plain sound wave that is sent against to a gypsum sample in front of a reverberant termination.

The resulting sound pressure is measured by two microphones of ICP 1/4" in front of sample.

The sound absorption coefficient of material is determined by evaluation the incoming and reflected sound energy by a Data Acquisition System to a PC that used an MATLAB R12b Program for interpretation of data (Fig. 7).

The samples have a cylindrical shape with a diameter of 100mm and a thickness of 25mm. Each test was repeated with at least five samples to obtain the average results, and made at the temperature of $(20 \pm 2)^\circ\text{C}$ and relative humidity of $(60 \pm 10)\%$.

3. Results and discussion

3.1. Fabrication of gypsum with microwave energy

Analyzing the microstructure of samples from Figs. 4-6, can be observed that between samples of β -construction gypsum plaster (Fig. 4) and m -gypsum plaster (Fig. 5) exist a similitude of grain structure, which means that the gypsum plaster, obtained in a microwave range at temperatures of 200-300°C and normal pressure, it is a variant of construction gypsum plaster. For determination of other main characteristics, it is necessary a great quantity of material, which can obtain only in big ovens or pilot stations.

The α -modeling gypsum plaster manufactured at "Congips"Co. is successful used in fabrication of sound absorption panels with size of 600x600x24.5/50 mm, and in orthopedic technique to obtain the dressing and lightweight prosthesis orthopedic (Fig. 8).

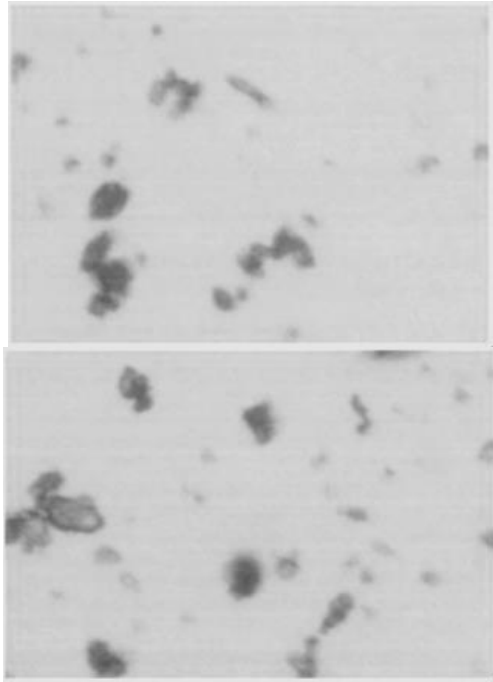

Fig. 8. Microscope structure of α -modeling plaster impregnated in orthopedic dressing, magnitude of 500X

It knows that in medical fields, the gypsum material required specific treatment vs. engineering applications. In this sense, it was integrated the α -modeling gypsum plaster with β -modeling gypsum plaster by adding white cement, dehydrated lime, and as accelerators potassium sulfate, gypsum particles, retarders-borax, colloids, and the filler-silica and resin.

The disinfection made with silver and other compounds or solutions with the antiseptic aim.

These using of α -modeling gypsum plasters in orthopedic technique are yet in research phase.

Some researches and tests employed a good collaboration between authors, "Congips" Co. of Oradea and "Rehabilitation Clinical Hospital" of Felix Spa.

The results of experiment showed that microwave energy could be using in the fabrication process of gypsum materials, at normal pressure and short time, which means high quality of materials, a great productivity and low costs.

The research and tests in lab and pilot station are not so expensive and easy for doing, and must be continuing to obtain new efficient gypsoms by using microwave energy.

3.2. Elastic characteristics of gypsum materials

3.2.1. Determination of elastic modulus

The tests used for determination of elastic modulus of gypsum family materials were been applied to three types of samples (denoted of Acg , Abs and Ort) under cylindrical shape by using an original installation, presented in Fig. 6.

Determination of propagation time passing through the cylinder (Fig.9) is made for the difference between the number of acquisition points for first strain gage (red color

is the initial time) and second strain gage (blue color is the final time), which is reported at the acquisition system rate of 1/250000.

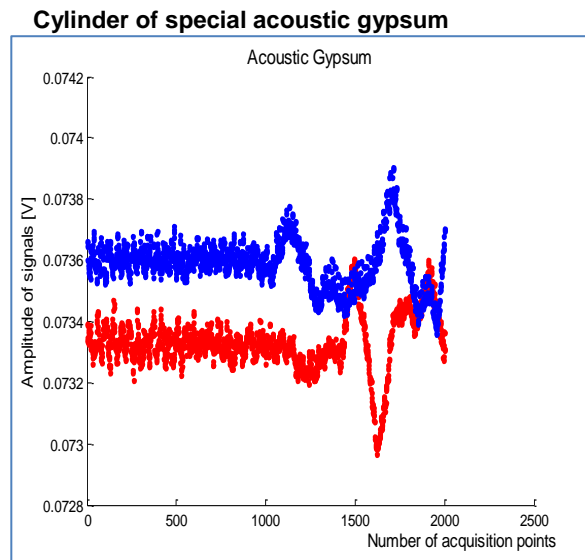

Fig. 9: Diagram for determination of propagation time passing through acoustic gypsum cylinder- Acg

The average propagation time for the cylinder Acg is $t_{Acg} = 2.950 \cdot 10^{-4}$ s and knowing the predictable distance between strain gages of 470mm can be determined the propagation velocity of waves passing through the sample, by used (7), and that is 1593 m/s. The values of E_{Acg} and G_{Acg} are presented in Tab.2.

Table 2: The values of E and G for the materials of gypsum family

MATERIALS	E [GPa]	G [GPa]
Acg	1.700	0.644
Abs	1.165	0.441
Ort	1.054	0.399

Cylinder of acoustic α -modeling gypsum plaster

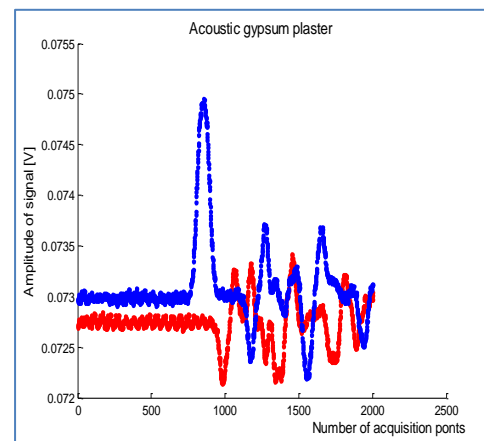

Fig. 10: Diagram for determination of propagation time passing through acoustic α -modeling gypsum plaster cylinder- Abs

The average propagation time for the cylinder *Acg* is $t_{Abs} = 3.591 \cdot 10^{-4}$ s and knowing the predictable distance between strain gages of 470mm can be determined the propagation velocity of waves passing through the sample, by used (7), and that is 1309 m/s.

The values of E_{Abs} and G_{Abs} are presented in Tab.2.

Cylinder of orthopedic α -modeling gypsum plaster

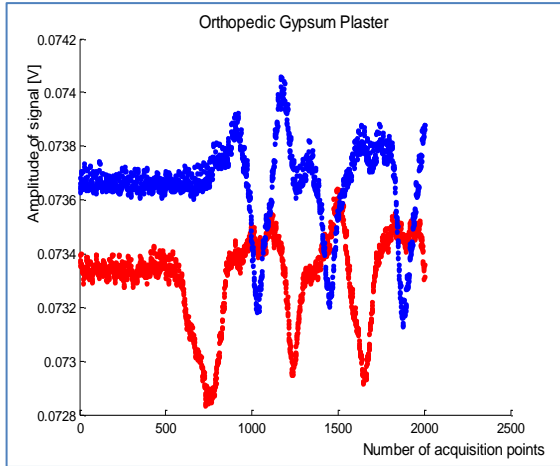

Fig. 11. Diagram for determination of propagation time passing through gypsum cylinder-Ort

The average propagation time for the cylinder *Ort* is $t_{Ort} = 3.885 \cdot 10^{-4}$ s and knowing the predictable distance between strain gages of 470mm can be determined the propagation velocity of waves passing through the sample, by used (7), and that is 1210 m/s.

The values of E_{Ort} and G_{Ort} are presented in Tab.2.

In general, there are used multiple methods for determination the elasticity modulus of construction

materials, where for gypsum are based on stress-strain diagrams obtained from compression tests of gypsum samples.

Paper [18] presents a method for determination of the gypsum board for fire protection by subjected the sample at load and deflexion in three-point bending test, in conformity with ASTM E-119, obtain the values of $E = (1.7-2.5)$ GPa.

For a gypsum reinforced with cellulose fibers [12] that used the same mechanical tests was obtained the values of $E = (3.88-7.43)$ GPa.

As an average value of normal gypsum can be considering the value of 2GPa, which are could differently sizes in function of its receipt and type of gypsum, and of course by the application fields.

Analyzing the results of our experiments, where the gypsum materials with special applications (acoustic/thermal isolator of buildings and medicine) and original receipts, the average values of $E = (1.054-1.7)$ GPa can consider acceptable.

In addition, these results confirmed the methods and installation used for determination of E applied on gypsum family materials, and carrying on the research to extend on other construction materials or some metals, as Cu and Al.

3.2.2. Determination of sound absorption coefficients

The tests used for determination the sound absorption coefficients of gypsum family materials were been applied to three types of samples (*Acg*, *Abs* and *DABs*) under cylindrical shape by using an installation with impedance tube type AFD 1000-AcoustiTube, presented in Fig. 8.

The installation was set to the frequency of (50-2000) Hz with a rate of 50Hz.

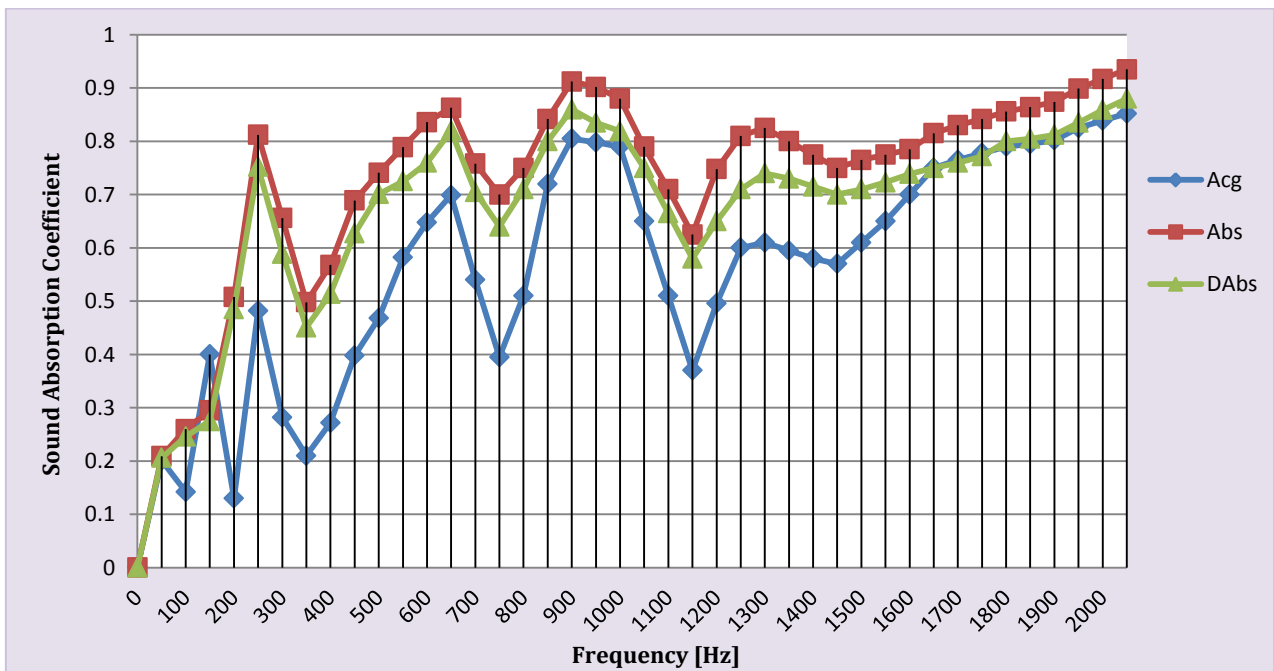

Fig. 12. Diagrams of sound absorption coefficients of gypsum family materials

Analyzing the diagrams of Fig. 12, we can observe that the best result of sound absorption coefficients along entire frequency range of testing has the samples of acoustic α -modeling gypsum plaster (*Abs*).

Very near with (*Abs*) kept the similar samples – (*Dabs*), painted with dispersil to withstand the humidity for outside acoustic panels.

By painting of samples, the sound absorption coefficient had an average decrease size of 4%, which are acceptable for their applications.

In addition, the acoustic gypsum samples - (*Acg*) had a significant improvement vs. normal gypsum, in special at medium and high frequency.

For the *Abs*-samples, the maximum values of sound absorbing coefficients are $\alpha_{Abs} = 0.935$ at 2000Hz and $\alpha_{Abs} = 0.912$ at 900Hz, respectively.

Similar for *Dabs*-samples, the maximum values of α_{Dabs} -coefficients are lower with 6%, such as $\alpha_{Dabs} = 0.880$ (2000Hz) and $\alpha_{Dabs} = 0.860$ (900Hz).

The acoustic gypsum samples have the higher α_{Acg} -values lower vs. *Abs*-samples with 9% at 2000Hz by $\alpha_{Acg} = 0.852$ and with 12% lower at 900Hz by $\alpha_{Acg} = 0.805$.

At low frequency, the best results are at 250Hz, such as $\alpha_{Abs} = 0.812$, $\alpha_{Dabs} = 0.752$ and $\alpha_{Acg} = 0.482$.

As a general conclusion can be affirmed that all the gypsum family samples presented a good acoustical behavior on medium and high frequency, which recommend them for using as isolator panels of buildings and sonic barriers along the highways or in front of main public institutions.

4. Conclusions

This paper represented a complex study that focused on presentation of practical and original solutions for determination the elastically characteristic of gypsum family materials with special applications in isolators of buildings, sonic barriers along the freeway, dressings and lightweight orthopedic corsets.

For testing, has used four types of gypsum from special acoustic gypsums and modeling gypsum plasters with original receipts, subjected at multiple tests by modern installations to obtain elastically modulus and sound absorbing coefficient of gypsums.

A novel fabrication process of gypsum by heating in the microwave field of clean breakage gypsum has used to obtain new composites with superior properties and high productivity, demonstrated that gypsum is a natural dielectric material with losses.

The experimental results confirm the methods and original installations used at testing, and higher properties of these new composites from gypsum family, especially for the acoustic alpha-modeling gypsum plaster with both inner and outside applications.

The future study would be carrying on to determination of new efficient gypsum plasters with special applications and implementation a pilot station of microwave energy for

heating of gypsum to extend this process at the industrial scale.

Acknowledgements

This work has financially supported by “Domus Hungarica Scientenarium et Atrium” Grants from “Hungary Technical Academy” of Budapest. The authors gratefully acknowledge for the technical support to “Congips” Co. of Oradea and “Rehabilitation Clinical Hospital” of Felix Spa.

References

- [1] D. T. Liu, K. F. Xia, R. D. Yang, J. Li, K. F. Chen, M. M. Nazhad, J. Compos. Mater. **46**(9), 1011, (2012)
- [2] A. Hedayati, A. Arefazar, J. Reinf. Plast. Comp. **28**(18), 2241, (2009)
- [3] H. S. Seddeq, N. M. Aly, A. A. Marwa, M. H. Salka Journal of Industrial Textile (FIT), **0**(0/0), 1 (2012)
- [4] M. Yuan, H. Ji, J. Qiu, T. Ma, J. Intel. Mat. Syst. Str. **23**(7), 791, (2012)
- [5] D. Liu, K. Xia, W. Chen, R. Jang, B. Wang, J. Compos. Mater. **46** (4), 399, (2012)
- [6] G. Thilagavathi, E. Pradeep, T. Kannaian, L. Sasikala, Journal of Industrial Textile, **39**(3), 267, (2010)
- [7] S. V. Shepel, K. G. Wakili and E. Hugi, J. Fire Sci. **30**(3), 240, (2012)
- [8] T. Meng, H. Hong-Xing, J. Vib. Control **18**(1), 48, (2011)
- [9] K. G. Wakili, E. Hugi, J of Fire Sci, **27**, 27, (2009)
- [10] S. Meille, E.J. Garboczi, Model. Simul. Mater. Sc. **9**, 371, (2001)
- [11] C. Toscano, C. Meola, G. M. Carlomagno, Journal of Composites, **2013**, Article ID 140127, 8 pages, (2013), doi:10.1155/2013/140127
- [12] M. A. Carvalho, C. C. Junior, H. S. Junior, R. Tubino, M. T. Carvalho, J. Mater. Res. **11**/4, 391(2008)
- [13] A. B. Strong, Fundamentals of composite manufacturing. Materials, methods and applications, Second Edition, SME Ed., Dearborn, MI, USA, (2008)
- [14] B. Morey, Manufacturing Engineering Magazine, **142**/3, 49, (2009)
- [15] P. A. Pop, P. A., Ungur, L. Lazar, M. Gordan, F. Marcu, Proceedings of ASME Congress & Exposition IMECE 2012, Houston, TX, USA, 2012, p. 1-7
- [16] H. Zhou, B. L. Li, G. S. Huang, J. He, J. Sound Vib. **304**, 400, (2007)
- [17] H. Zhou, B. L. Li, G. S. Huang, J. Appl. Polym. Sci. **101**, 2675, (2006)
- [18] S. M. Cramer, O. M. Friday, R. H. White, G. Sriprutkiat, Proceedings of the Fire and Materials 2003 Conference, San Francisco, CA, USA, 2003, p. 33-42.

- [19] G.F. Schrader, A.K. Elshennawy, Manufacturing process and material, Fourth Edition, SME Editor, Dearborn, MI, USA, (2000)
- [20] P. A. Pop, P. A., Ungur, A. Caraban, F. Marcu, 3th Manufacturing Engineering Society International Conference MESIC-09, Book Series: AIP Conference Proceedings, Vol. 1181, 2009, p. 334-344
- [21] SR EN ISO 1587/1996, Gypsum, Romanian Standard from ISO, Bucharest
- [22] SR EN ISO 13279-1/2005, Gypsum binder and gypsum plaster. Definitions and conditions, Bucharest
- [23] SR EN 13273-2/2005, Gypsum binder and gypsum plaster. Part 2: Test methods, Bucharest
- [24] A. Nicula, F. Puscas, Dielectrics and ferroelectrics, Romanian Writing Ed., Craiova, (1982)
- [25] F. J. Crawford Jr., Course of Physics-Berkeley, Vol.3, Translated from English, Didactical and Pedagogical Editor, Bucharest, (1983)
- [26] G. B. Collins, *Microwave Magnetron*, McCrow Hill Book, Vol. II, London, (1948)
- [27] F. P. Lewis, Magnetrons Muni Dun Blingage, Patente France, Nr.2680912/05.03.1993
- [28] P. Ungur, P. A. Pop, M. Gordan, C. Gordan, Proceedings of ASME-MSEC/ICMP2008 Evanston, IL, USA, ASME International & JSME, 2008, p.1-9
- [29] P. A. Pop, P. A., Ungur, L. Lazar, F. Marcu, Proceedings of ASME-MSEC 2010 Conference, 2010, Erie, PA, USA, p.1-8.
- [30] Dubbel, Handbook of Mechanical Engineering, Technical Editor, Bucharest, (1998)
- [31] Brochure of AFD 1000, AFD mbh Dresden, Germany, 2011, www.akustikforschung.de

*Corresponding author: adippop@yahoo.com