

Novel automated inclined rotating substrate for DSSC fabrication

V.SENTHILNATHAN*, S.GANESAN^a, S. SENTHILNATHAN^b, V. VIJAYAKUMAR GANDHI^c

Department of Physics, Kumarakuru College of Technology, Coimbatore-641 006, India.

^aDepartment of Physics, Government College of Technology, Coimbatore 641 013, India

^bnathas.com research ideas center, Saravanampatty, Coimbatore- 641 035, India

^cLarsen & Toubro Ltd., KKNPP project site, Kudankulam, India – 627 106, India

In the current scenario of energy requirements solar cell is one of the important pollution free energy converter. In photovoltaic field Dye-Sensitized Solar Cell (DSSC) is one of the most promising method for a high-performance solar cell in the next generation, since it is fabricated by a simple manufacture process at relatively low cost. The focus of interest in this research paper is to mention the fabrication & working of this novel single & simple apparatus of microcontroller aided SPTD (Spray Pyrolysis Thin film Deposition) for fabricating the electrode and counter electrode for DSSC. It involves the novelties introduced in the instrumentation of the apparatus and the characterisations (XRD, SEM & AFM) of the prepared thin films for the fabricated DSSC. (In this novel apparatus design, TiO₂ thin film formation is happening by spin cum spray pyrolysis). The grape fruit skin dye is used to sensitize the Nano TiO₂ thin films. The thin films prepared by this novel method are tested for its DSSC performance. The results are in agreement/matching with conventional methods. The efficiency of assembled DSSC is 0.24%.

(Received September 14, 2010; accepted November 19, 2010)

Keywords: DSSC, Automatic intermittent Spray Pyrolysis, Microcontroller, inclined rotating substrate, Thin films, Grape fruit skin dye

1. Introduction

Spray Pyrolysis Thin film deposition (SPTD) method of thin film preparation is a simple and versatile method of making thin films and multilayered films [1,26]. Thin films are used in different applications like Solar cells, optoelectronics, sensors etc. This technique had been used in research to prepare thin and thick films, ceramic coatings, and powders [1]. It had been used for several decades in the glass industry [8] and in solar cell production [9]. Spray pyrolysis represents a very simple and relatively cost-effective processing method (especially with regard to equipment costs). The typical spray pyrolysis equipment consists of an atomizer, precursor solution, substrate heater, and temperature controller [43]. The method involves spraying a solution containing precursors onto a heated substrate. Sprayed droplets or residual particles reaching the hot surface undergo pyrolytic decomposition and form a single or a polycrystalline film. The quality and properties of the films depend largely on the process parameters. The most important parameter is the substrate surface temperature [1,5,14,26]. The properties of deposited films can be varied and thus controlled by changing the deposition temperature [1,2,3,17,21,26]. The substrate temperature has influences over the resulting optical and electrical properties of SnO-F, ZnO films [21,16,19,26]. Hence, in many of the reported research papers it has been stated that an intermittent spray was preferred in the spray coating process for getting a good thin film material formation [19,20,21,26,18,9,10,11,12,13]. In the time gap between

the two successive sprays of a series of sprays the substrate temperature (T_s) and the air medium above the substrate are restored to its initial levels of preferred temperature.

In this work the SPTD equipment is fabricated. Here, an economical microcontroller [44,45] is linked with it to improve the quality of the thin film by making use of user defined intermittent spray, ventilation and substrate motion. All these functions are simultaneously done by tapping the out put from the microcontroller. Hence, once the details are set, then it's almost an automatic coating. This developed system is useful to prepare thin film materials [4,6,19,21,10,13] for DSSC applications. Nano SnO-F, TiO₂ thin films are prepared using this apparatus and assembled to get the DSSC. The grape fruit skin dye is used for sensitizing TiO₂ [46,48,51]. This automation of intermittent spray helps to do the experiment without error for the defined time durations till the completion of the spray process.

2. Material and methods

2.1. Innovative design using microcontroller

It had been conclusively proven that intermittent spray [19,21,26] has advantages over continuous spray. In SPTD precisely managing the timings of an intermittent spray (spray time and spray pause time) with out any error will lead to the creation of good thin film quality [19,21,26]

and reproducibility of thickness. A micro controller device [44,45] can easily and efficiently handle this task.

The block diagram of the microcontroller and its interface with the fabricated spray pyrolysis set up is given in Fig.1. The microcontroller timer circuit and its accessories circuit is given in figure.2. The photograph of the microcontroller and its interface with the spray pyrolysis is given in Fig.3 and 4 respectively.

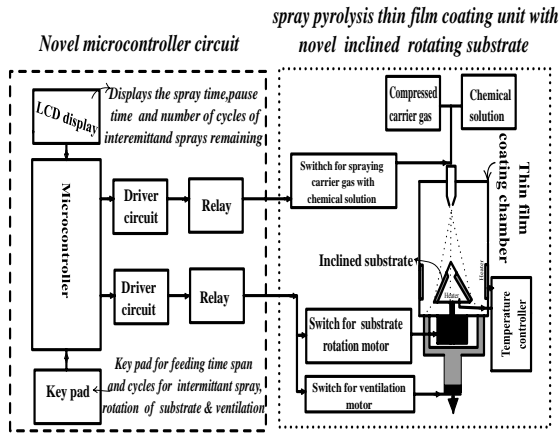

Fig.1. Block diagram of the newly developed spray pyrolysis set up

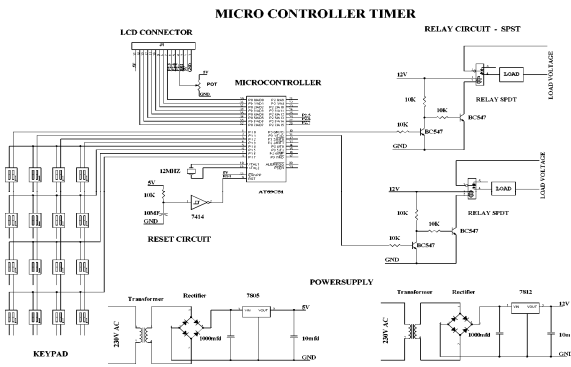

Fig.2. The overall circuit diagram of the microcontroller circuit.

2.2. Need of an inclined rotating substrate

Considering the point stressed by the Dainius Perednis et al [1] and similar works [30,31,32] an inclined rotating substrate is implemented in this research project. This inclined substrate design facilitates for most of droplets to strike the substrate and spread [1,30,32,33]. (A design patent is filed in India in this regard). A slow speed motor (60 rpm) kept at the outside bottom of the coating chamber rotates the cone shaped structure inside the chamber [31]. On the outer surface of the cone shape inclined substrate holders were positioned.

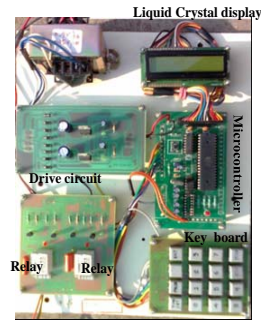

Fig.3. Photograph of the microcontroller circuit



Fig. 4. Photograph of the microcontroller circuit & inclined substrate for spray pyrolysis set up.



Fig. 5. Photograph of the inclined substrate

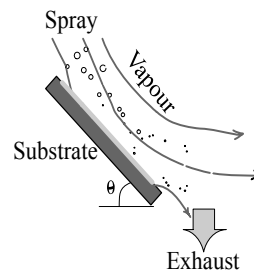

Fig. 6. Aerosol transport on an inclined substrate

The circular rotation of the substrate helps for the spreading of the splashing droplet on it due to centrifugal force [30,31]. The Photograph of the novel inclined rotating substrate holder is given in Figure.5. The cone structure is filled inside with metal filling for absorbing

and storing the thermal energy. The temperature sensing probe is in contact with the cone. Its temperature and its ambient temperature are heated up by the electric furnace arrangement. A Chrome alumel thermocouple is used to sense the temperature of the substrate. The substrate is kept at a fixed temperature (T_s) with the help of a digital temperature controller device. When, all these are synchronized with the microcontroller out put for a simultaneous on and off settings, it ultimately helps to ensure reproducibility of the thin film [27].

Dainius Perednis & et al [1] had analysed the spray pyrolysis aerosol transport in detail. They reported that in an aerosol the droplet is transported and eventually evaporates. During transportation it is important that as many droplets as possible are to be transported to the substrate without forming powder or salt particles. The research investigations done by Sears et al [29] in this regard about the mechanism of SnO₂ film growth was also reviewed by them. The influence of forces which determine both the trajectory of the droplets and evaporation were examined and a film growth model was proposed by Sears et al. Gravitational, electric, thermophoretic and Stokes forces were taken into account by them.

Dainius Perednis & et al [1] reported that Sears et al had overestimated the role of thermophoretic forces. It was concluded that the film grows from the vapour of droplets passing very close to the hot substrate in a manner of chemical vapour deposition and droplets that strike the substrate form a powdery deposit. He had also highlighted an important point that needs to be considered is the spreading of droplets on the substrate, which more significantly contributes to the film growth. In the spray pyrolysis process it is desired that the most droplets strike the substrate and spread. These, points are taken in to account by the researchers and hence an inclined substrate and its rotation were carried out by them successfully. [1, 27,28,30,31,33]. The aerosol transport on an inclined substrate is given in Figure.6.

2.3. Testing & Optimization of the fabricated equipment

The working of the fabricated SPTD device along with the novel ideas are tested and optimised by the following simple steps/methods (due to lack of facility). This helps to understand the aerosols transport and thin film formation and compare the earlier reported modeled and experimental works [34,35,36,30].In this the fluid dynamics happening inside the coating chamber is analysed by spraying dark blue colour ink solution through the nozzle jet and covering the inner lining of the chamber with white background. This is repeated also at high temperature for every 2 seconds of colour solution spray on the cone surface with glass substrate. The trajectory of the aerosols and the formation of blue colour over the glass surface are photographed for analysis. Here, the glass

substrate was coated with colour. This gives the details about the active aerosol trajectory and the possible deposition regions. In an actual experiment the pyrolysis action takes place. So, test is repeated with SnO₂-F, TiO₂ thin film experiments to ascertain the uniform thin film formation [34,31]. The height of the substrate is also adjusted to repeat the experiment and the optimum distance between the nozzle and the substrate is also optimised (25 Cm).

The Cone shaped metallic structure is also optimised by changing the semi vertical angle of the cone and found to match with the earlier work of 40° [36,30,32].Uniform thin film formation is produced for an inclination of 40°angle. The ventilation happening inside the chamber was verified by filling the chamber with smoke and then the spray was done for 2 seconds along with air suction ventilation. The air turbulence inside the chamber was controlled and allows thin film formation even when the circular motion of the substrate is activated. The microcontroller circuit necessary for the automatic intermittent spray is fabricated. The working of microcontroller circuit checked with the spray pyrolysis apparatus. A mathematical model was developed [20] for the prediction of film thickness deposited using spray pyrolysis and it's used here to optimize the fabricated SPTD apparatus and the accessories.

2.4. Chemicals preparation

The stannous chloride (SnCl₂ 5H₂O) with fluorine (F) doping (15 % wt) was achieved by adding ammonium fluoride (NH₄F) [26]. The F-doped SnO₂ conducting layer (FTO, ~10 Ω/sq) is prepared above the 1mm cleaned glass plate glass substrate. The prepared FTO layers (~2.8 μm) are used in the front (electrode) and back side (counter electrode) electrodes for the DSSC. The substrate temperature is maintained at 430° C. The spray duration is for 2 seconds and paused for 2 minutes for the substrate to restore to its pre set 430° C.

In this work the Compact Layer (CL) & mesoporous films of TiO₂ [12,39] preparation step is a hybrid of the spin [12,36,38] & spray pyrolysis [39,40,41] using the novel substrate holder design. It is a completely different and simple method than the reported pyrolysis methods [40,41]. The design allows the spin and spray pyrolysis to occur at the same time and hence comparatively quicker, homogenous and reproducible thin film formation is achieved. The splashing of the (SPTD) sprayed aerosols on glass plates located on the rotating inclined substrate has led to the formation of thin film. The rotation of the inclined substrate makes it distributed over the glass substrate [38]. This process is a combination of conventional spray pyrolysis and spin coating of thin film formation.(The usual spin coating is more time consuming process).

Alcoholic solution of Titanium (IV) Isopropoxide (Sigma Aldrich) is used. The solution is sprayed on pre cleaned glass (1mm thickness) glass substrate having F-doped SnO_2 conducting layer (FTO, $10 \Omega/\text{sq}$) which is maintained at 100°C . Using the above mentioned microcontroller circuit for 2 seconds spraying & substrate rotation first followed by an interruption of 30 seconds to avoid excessive cooling of the substrate during the spray. This cycle was repeated for 20 times then the films were sintered at 500°C for 1 hr and cooled to room temperature to get $\sim 100 \text{ nm}$ thick dense TiO_2 layer. The spraying process was done with a glass nozzle, using compressed and purified gas.

The resulting pinhole free compact layer of TiO_2 which prevents the short circuiting of the cell [12,40]. Using the same approach the spray cycles were repeated for 100 times for getting a $6 \mu\text{m}$ thickness of mesoporous TiO_2 films on the CL layer. In this alcoholic solution of Titanium (IV) Isopropoxide (Sigma Aldrich) (0.09M concentration in ethanol medium) with 10 drops of HNO_3 is used. Then, the films were sintered. Then, it is annealed at 500°C and not beyond it [42] for increasing the crystallinity of the TiO_2 and for adhesion dye [42]. The grape fruit skin is extracted and it is used to sensitize the TiO_2 as per the reported method [46, 51]. This completes the formation of TiO_2 electrode for the DSSC.

The prepared SnO-F thin film is taken and above SnO-F graphite (manual pencil) coating is applied and above that carbon black is applied by exposing it uniformly over the candle flame. This is a simple and economic method to get the counter electrode. Between the electrodes, a $50\mu\text{m}$ space was retained using a pair of PTFE film spacer and electrolyte was injected into the space. The electrolyte composition was 0.03 M I₂ and 0.5 M KI in ethylene carbonate/acetonitrile (80:20, v/v) [50]. The assembling of the DSSC components are carefully done here [47,48,49] to get the DSSC for further photovoltaic analysis. The Schematic diagram representing the DSSC layers (side view) is given in Fig.10.

2.5. IV characteristics details

The I-V characteristics of the devices in the dark and under illumination (in figure 9) were measured by a semiconductor parameter analyzer (Keithley 4200-SCS). A xenon light source (Oriel, USA) was used to give a irradiance of $100 \text{ mW}/\text{cm}^2$ (equivalent to AM1.5 irradiation) at the surface of the device. The photoaction spectrum of the devices was measured using a monochromator (Spex 500 M, USA), and the resulting photocurrent was measured with a Keithley electrometer (model 6514), which is interfaced to the computer by LABVIEW software. The assembled DSSC has 0.24% efficiency; this is without platinum counter electrode, costly TCO (Indium Tin oxide).

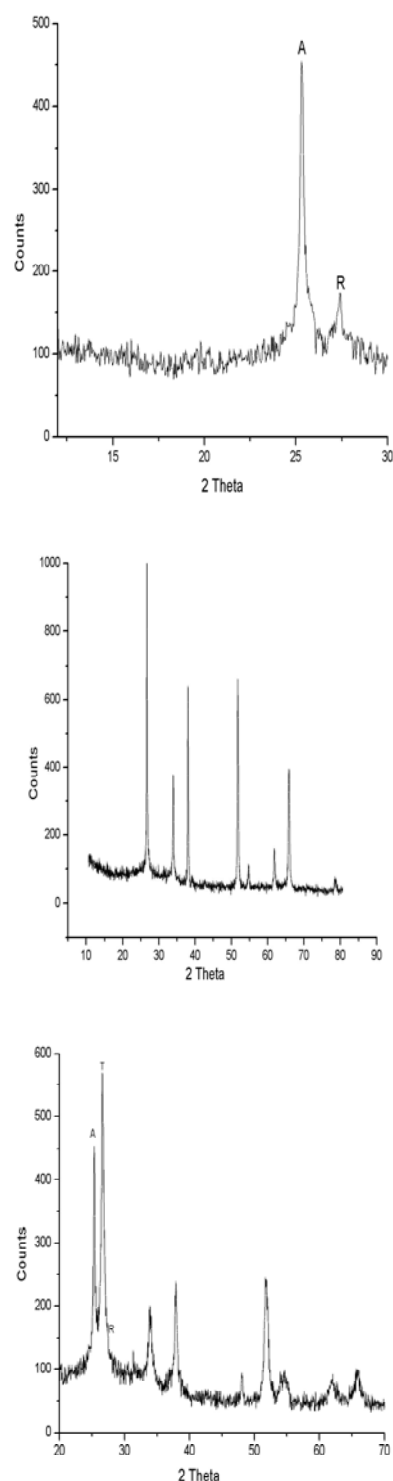

Fig. 7. (a) XRD of TiO_2 on glass substrate, (b) XRD of SnO-F on glass substrate, (c) XRD of SnO-F & TiO_2 on glass substrate

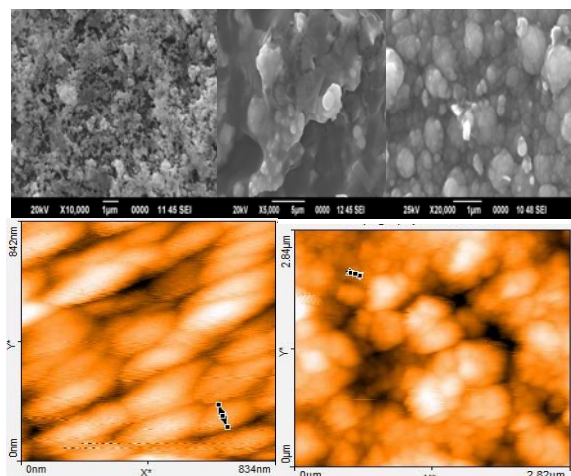

Fig. 8. SEM images: (a) Mesoporous TiO_2 , (b) TiO_2 & pomegranate fruit dye, (c) SnO-F. AFM images: (d) Mesoporous TiO_2 , (e) SnO-F.

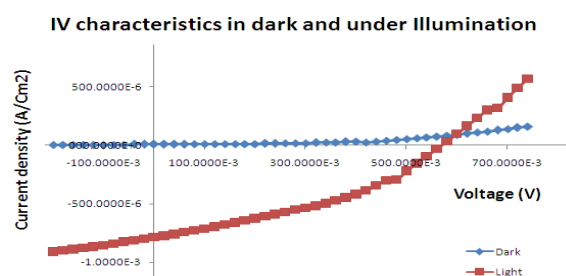

Fig. 9. The current (vs) voltage graph of the prepared DSSC under dark and illumination.

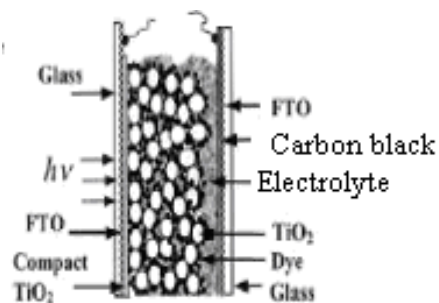

Fig. 10. Schematic diagram representing the DSSC layers (side view). The thickness of the thin film layers from right: 1mm glass plate, 2.8 μm FTO layer, 6 μm sensitized nanoporous TiO_2 , 100nm compact anatase TiO_2 layer, 2.8 μm FTO layer, 1mm glass plate.

Table 1.

Voc (V)	Isc (Amp/cm ²)	V mx (V)	Imx (Amp/cm ²)	Pin (mw/cm ²)	Fill factor	Efficiency %
0.57	0.789×10^{-3}	0.252	0.475×10^{-3}	5.00×10^{-2}	0.266	0.24

3.Result and discussion

The photovoltaic results are in agreement/matching with conventional methods [46]. The efficiency of assembled DSSC is 0.24%. The current (vs) voltage graph of the prepared DSSC under dark and illumination is given in figure.9. and its respective values in table.1. Using this economic device thin film like TCO (SnO-F) and TiO_2 are prepared for studying / manufacturing Dye Sensitised Solar Cell (DSSC). The XRD of these are given in figure 7(a),7(b)&7(c). Its standard peaks indicate the polycrystalline nature confirming presence of the elements (as per the JCPDS data: 04-0477 for Anatase TiO_2 ; 3-1276 for Rutile TiO_2 & 41-1445 for SnO-F) in nano crystal size range (TiO_2 :~30nm; SnO-F:~40nm). Using them a DSSC is prepared using grape fruit skin dye. The SEM images of the prepared Nano TiO_2 TiO_2 sensitised with natural dye extracted from grape fruit skin dye & SnO-F are given in figure.8(a),8(b) & 8(c). The AFM images of the TiO_2 : Fig. 8(d) Mesoporous TiO_2 & SnO-F are given in figure Figure.8 (d) & Figure.8 (e). These also confirm the nano particle thin film formation. It also reveals that the mesoporous surface morphology of TiO_2 and rough surface of SnO-F. The thin films are homogeneous and reproducible. The thickness of thin film prepared is also variable in accordance with DSSC application [20].

4. Conclusion

The characterisation of the prepared TiO_2 & SnO-F thin films shows that the pyrolytic reaction has been taking place normally. The whole intermittent spray processes was automatic and hence a good quality thin film coating was achieved every time. The novel inclined rotating substrate design has helped to do a hybrid of spray pyrolysis and spin thin film deposition leading to quicker and homogenous thin film deposition of Nano TiO_2 . A DSSC was fabricated using grape fruit skin dye with an efficiency of 0.24%. The result is encouraging when it is compared with similar DSSCs prepared by conventional methods [46,51]. Thus it can be refined to fabricate small scale DSSC manufacturing. The efficiency of DSSC can be improved with different dyes, electrolytes etc. In this research work a maiden attempt for a single & simple SPTD apparatus for fabricating homogeneous and reproducible electrode and counter electrode thin films for DSSC is prepared successfully. Other thin film preparations can be attempted using this apparatus for various applications. This microcontroller may be modified accordingly for automating spin, dip coating of thin films.

References

- [1] Dainius Perednis & et al, Journal of Electroceramics, **14**,103 (2005).
- [2] W. A. Bryant, J. Mater. Sci., **12**(7), 1285 (1977).
- [3] R.N. Ghoshtagore, J. Electrochem. Soc., **125**(1), 110 (1978).

- [4] M. Okuya & et al, J. Euro. Ceram. Soc., **21** (2001) 2099.
- [5] J. Hirunlabh & et al, Thammasat Int. J. Sc.Tech., **3**(2), (1998).
- [6] K. Murakami, I. Yagi, S. Kaneko, J. Am. Ceram. Soc., **79** (1996) 2557.
- [7] G. Montavon & et al, Surface and Coating Technology, **91**, 17 (1997)
- [8] C. J. Brinker & et al, Thin Solid Films, **201**(1), 97 (1991).
- [9] Y. Caglar & et al, The European Physical Journal B. Euro . Phys. J.B. **58**, 251 (2007)
- [10] Masayuki Okuya & et al, Journal of Photochemistry and Photobiology A: Chemistry **164**, 167 (2004F).
- [11] Eui-Kyung Oh and Sun-Geon Kim., Modeling And Measurement of Aerosol Deposition On A Heated Substrate, Aerosol Sci. **27**(8), 1143 (1996).
- [12] M. O. Abou-Helal, W. T. Seeber, Applied Surface Science **195**, 53 (2002).
- [13] Dwight R. Acosta & et al, Journal of Molecular catalysis A: Chemical **228**, 183 (2008).
- [14] J. M. Mochel, US Patent **2**(564), 707 (1951).
- [15] J. E. Hill, R.R. Chamberlin, US Patent **3**(148), 084 (1964).
- [16] A. R. Balkenende & et al, Philips Journal of Research, **50**(3-4), 365 (1996).
- [17] S. P. S. Arya & et al, Thin Solid Films, **193**(1-2), 841 (1990).
- [18] Monica-Loredana ENESCU, The automatized systems for spray pyrolysis deposition, the automatized systems for spray pyrolysis deposition, ANNALS Of The ORADEA UNIVERSITY. Fascicle of Management and Technological Engineering, Volume VII (XVII), 2008.
- [19] S. M. Rozati, Sh. Akeste, Cryst, Res, Technol, **43**(3), 273 (2008)
- [20] V. Senthilnathan et al, International Journal of Material Science, ISSN 0973-4589, **4**(1), 31 (2009).
- [21] H. H. Afify & et al, J. Mater. Sci.: Materials in Electronics, **2**(3), 152 (1991).
- [22] N. H. J. Stelzer, J. Schoonman, J. Materials Synthesis and Processing, **4**(6), 429 (1996)
- [23] B. Elidrissi & et al, Thin Solid Films **379** (2000)
- [24] C. M. Mahajan, M. G. Takwale. IEEE Xplore. Digital Object Identifier: 10.1109/IWPSD.2007.4472671, Print ISBN: 978-1-4244-1728-5, INSPEC Accession Number: 9866740 2007.4472671.
- [25] Anca Duta et al., Anatase (TiO₂) thin layers for solar energy conversion. IEEE Journal.
- [26] E. Elangovan, K. Ramamurthi, J. Optoelectron. Adv. Mater. **5**(1), 45 (2003).
- [27] M. O. Abou-Helal, W.T. Seeber, Applied Surface Science **195**, 53 (2002).
- [28] Hongwei Han & et al, Journal of Materials science (2005).
- [29] W. M. Sears, M. A. Gee, Thin Solid Films, **165**(1), 265 (1988).
- [30] A. Simashkevich & et al, Moldavian Journal of the Physical Sciences, **3**(3-4), (2004).
- [31] Xiaoming Huang, & et al, Journal of Renewable & Sustainable energy **1**, 063107 (2009).
- [32] Arturo I Mart'inez & et al, J. Phys.: Condens. Matter **16** (2004) S2335-S2344 PII:S0953-8984(04)76417-6.
- [33] Eui-Kyung Oh & et al, J Aerosol Sci, **27**(8), 1143 (1996).
- [34] Pramod S. Patil, Materials chemistry and physics **59**, 185 (1999).
- [35] Niinisto, Journal of thermal analysis and calorimeter **56**, 7 (1999).
- [36] Shuxin Tan & et al, Langmuir, , **20**(7), 2934 (2004).
- [37] A. Simashkevich & et al, Moldavian Journal of the Physical Sciences, **3**(3-4), (2004).
- [38] Chung-Hsin Lu et al, Journal of Hazardous Materials **147**, 33 (2007).
- [39] G. K. R. senadeera & et al, Bull. Mater. Sci. **28**(6), 635 (2005)
- [40] F. O. Lenzmann & et al, Prog. Photovolt: Res. Appl.; **13**, 333 (2005) (DOI: 10.1002/pip.631).
- [41] Kavan L, Gra'tzel M. Electrochimica Acta; **40**(5), 643 (1995).
- [42] Kun-Mu-Lee & et al, Solar energy Materials and Solar Cells, **91** 1416 (2007).
- [43] Bhavana Godbole & et al, Jl. of Instrum. Soc. of India **39**(1), 42 (2009).
- [44] L. Shrimanth Sudheer & et al, Jl. of Instrum. Soc. of India **39**(1), 62 (2009).
- [45] A. Joseph Nathanael & et al, Jl. of Instrum. Soc. of India, **38**(2), 91 (2009).
- [46] Yang-Sian Chen & et al, Proceedings of ICAM2007, Nov. 26-28, 2007, Tainan, Taiwan, Manufacture of Dye-Sensitized Nano Solar Cells and their I-V Curve Measurements.
- [47] Bin Li & et al, Solar energy materials & solar cells, **90**, 549 (2006).
- [48] Greg P. Smestad and Michael Gratzel, Journal of chemical education, **75**(6), 752 (1998).
- [49] G. Calogero, G. Di. Marco, Solar Energy Materials & Solar Cells **92**, 1341 (2008).
- [50] E. Yamazaki et al. / Solar Energy **81**, 512 (2007).
- [51] A. C. Muñoz-Espada & et al, J. Agric. Food Chem., **52**(22), 6779 (2004). DOI: 10.1021/jf040087y.