

Quantum sense: towards nanoparticle based smart sensors

K. NANDHINI, N. R. RAAJAN, R. KUMAR KARN
SASTRA University, Thanjavur, Tamil Nadu, 613402, India

This research work focuses on touch sensing, which is the burning issue in the field of smart vision. This research work has taken touch based system a step ahead by choosing the kind of coating that could be used in any device where a display is necessary. All kinds of materials like conductor, semi - conductor and insulator are taken and tested for sensing. Here, thin film of glass coated with various compounds like copper, copper oxide, indium tin oxide, combination of cadmium oxide and zinc oxide are tried. In addition to coating made on glass, titanium dioxide is coated on metal and checked for sensing of touch. A comparison is made among conductors, semi-conductors and insulators. The obtained results would indicate the kind of material that would be suitable for the application of touch sensing. It is also tested for various kinds of light. This would tell the material that would be suitable according to the prevailing lighting.

(Received January 8, 2015; accepted September 9, 2015)

Keywords: Touch, Sensing, Resistivity, Substrate, Quantum

1. Introduction

Nowadays, touch sensing is being widely used in all gadgets. In addition it is also being projected on any object using various techniques and that device acts as a touch display. Compounds such as copper, copper oxide, Indium tin oxide, combination of cadmium oxide and zinc oxide, Tin oxide are coated on various kinds of materials. They are being widely used in various applications from dentistry to antibacterial agents. The technique of coating varies based on the material taken and the stoichiometric ratio of various compounds that are to be taken. SVM is a kind of classifier that is used for the purpose of classification. It includes two phases namely training and testing.

The sample of the soil was obtained 44 years ago which had cadmium deposits. When the soil was tested after 44 years it was found that the cadmium was immobile and was constantly in touch with the soil. The cadmium was moving down the soil and the amount of soluble cadmium was found to decrease as the number of years was increasing. [21], [2] deals about the various properties of zinc oxide in the solid vapor phase. It also deals how ZnO could act as nanosensors, nanocantilevers etc. This also tells how zinc oxide could be molded from a simple material to a particular kind of application. [1] deals about improving the electrical and optical properties of the sputtered ZnO: Al films. This combination was tried for all. Fig. 1 shows the sputtering process namely RF, DC and MF to find which film had the best quality. It was found that the quality of the film was good using all three techniques.

2. Related Works

[18] Explains how transparent conducting oxides which use a combination of indium tin oxide along with other compounds could replace indium tin oxide. If such a replacement is done then the amount of ITO to be used would be reduced to half. However the best solution is to use indium free tin oxide. [9] explains how the sheet resistance and grain size are inversely proportional. [12] discusses about the touch application using TiO₂.

As silver has the property of antibacterial activity [5] used silver coated TiO₂ to test against Escherichia coli and Staphylococcus aureus. It was found that it proved to be an antibacterial agent and [14] explains that it could find its application in various walks of life. [6] proposes a technique based on frustrated total internal reflection. This turns out to be a simple and inexpensive technique which could be used for multi-touch sensing. This technique is widely used in biometrics and in applications that uses robot. [8] explains about the need for capacitance sensing in Touch Track-ball and Scrolling Touch Mouse such that it could detect whether there is contact between the users hand and the device.

[4] briefs about multi user and multi touch on a spherical display. Touch screens are very sensitive and precise techniques are to be adopted to make touch interaction easy. [3] proposes five different precise techniques that could be used in the multi touch screen. These techniques are used for performing various operations on the touch screen. [13, 17] discusses the importance of SVM classifier.

3. Experimental Details

3.1. DC Reactive Magnetron Spectrum

There are two magnetrons which are negatively charged. Argon gas was purged into a chamber by applying high potential. As a result of which argon gas was ionized and becomes Ar^+ ions. The rate of flow of Argon was 40 sccm. These ions are accelerated towards magnetron which is negatively charged. The kinetic energy of Ar^+ ions gets transferred to the target surface and the target material was ejected out and deposited on the substrate. Due to magnetic arrangement over the target it brings electrons in helical trajectory motion and focuses the deposition in the area of confinement. To improve the adhesion of deposited sample has been annealed in nitrogen atmosphere at a temperature of 550°C for 6 hours.

3.2. The Process to create a vacuum

Two valves are used in this process. They are: backing valve and roughing valve. Backing valve is used for the purpose of creating base pressure and the purport of roughing valve is to create pressure of about 10^{-3} bar. The process to create vacuum is as follows: After switching on the rotary pump, wait for five minutes and then open the backing valve. Wait for another five minutes and switch on the penning gauge and note the pressure. When the pressure reaches 45^{-3} bar close the backing valve. Next, open the roughing valve and wait until the pressure reaches around 10^{-3} bar. This is followed by switching on the diffusion pump. This is espoused by switching on the water circulation and cooler. After 30 minutes close the roughing valve and open the backing valve. Wait for 5 min and then open the high vacuum valve. When the pressure reaches 10^{-5} Bar in high vacuum, the deposition process is started. If the deposition is intended for the purpose of metal coating, argon is introduced into the deposition chamber and the DC current is applied to start deposition. For semi conducting coating, required amount of argon and oxygen is allowed simultaneously for deposition and then DC current is allowed.

3.3. Advantages of Technique

Uniform coating could be obtained. Large area coating is possible. Purity of film could be achieved to a greater extent. It is possible to fine tune the ratio of stoichiometry. In table 1 no represents no touch, one represents one finger touch and two represents two finger touch.

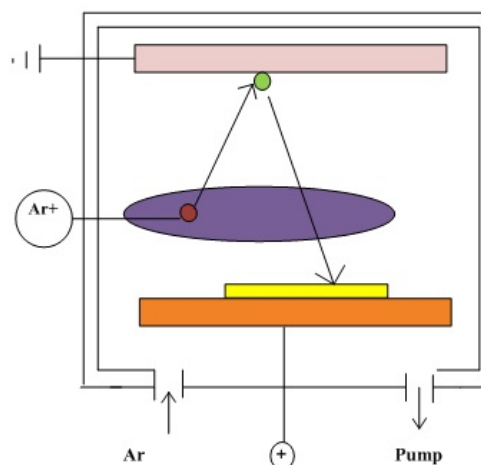

Fig 1: Sputtering Process

3.4 Microstructural chaacterizations (XRD)

The crystalline nature and the phases of the prepared nanoparticulate TiO_2 thin films was studied using X-ray diffraction analysis using PANalytical X'Pert PRO multipurpose diffractometer. The XRD patterns were recorded using $\text{Cu K}\alpha$ radiation and in the 2θ range of $10-80^\circ$.

3.5 Structural Characterization

The structural analysis of TiO_2 particles was carried out using XRD instrument. The diffractograms were recorded in the 2θ range of $10-80^\circ$. Figure 1 shows representative XRD patterns taken from Sol residues heated at 300°C for 2 h.

The crystalline nature was observed in the powder XRD of TiO_2 and diffraction peaks belong to rutile and anatase phase of TiO_2 . The broadening of peak represents nano size of the crystal. The XRD patterns exhibited diffraction peaks at 25.44° , 36.16° , 47.91° and 54.43° , 63.4° indicating TiO_2 in anatase phase with the corresponding (101), (103), (200), (105) and (204) planes respectively. The peaks observed at 27.47° , 41.20° , 56.62° , 69.35° indicating TiO_2 in rutile phase with the corresponding (110), (111), (220) and (301) planes respectively.

All observed peaks are in good agreement with the standard spectrum (JCPDS no.: 21-1272 and 21-1276). Average particle size was estimated by using scherrer equation.

$$\text{Grain size } D = \frac{.89\lambda}{\beta \cos\theta}$$

Where λ = $\text{Cu K}\alpha$ radiation Wavelength 1.549 \AA
 K = Shape factor

The Avg. particle size was calculated to be around 15-20 nm. TiO₂ thin film prepared with sputtering cycle. The peak positions were systematically indexed by comparing the pattern with the reference patterns (JCPDS Card Number: 21-1272 & 21-1276). The relative percentage of anatase and rutile phases was estimated as 54% and 46% using the relation [21],

$$X_A = \frac{1}{\left[1 + 1.265 \frac{I_R}{I_A}\right]} \times 100$$

where I_A is the (1 0 1) peak intensity of anatase phase, I_R is the (1 1 0) peak intensity of rutile phase and 1.265 is the scattering coefficient. The broad nature of full width at half maximum (FWHM) suggests the size broadening effect and the average crystallite size was 22 nm which was calculated using the Scherrer formula.

$$D = \frac{K\lambda}{\beta \cos\theta}$$

where $K = 0.9$, β is the full width at half maximum and θ is the Bragg peak position.

4. Results and discussions

Table 1: Resistivity values for various kinds of touch for various compounds

Compound	No touch	One finger touch	Two finger touch
Cu (C)	948	940	944
CuO (SC)	944	928	932
ITO (SC)	944	932	928
CdO & ZnO (SC)	944	925	932
Insulator	928	900	900
TiO ₂	944	924	892

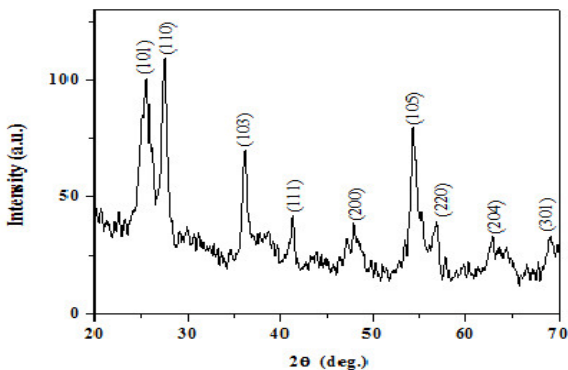

Fig 2. XRD graph

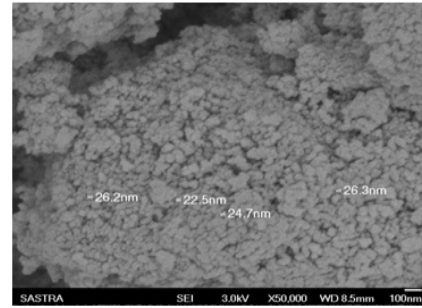

Fig. 3 SEM image of TiO₂

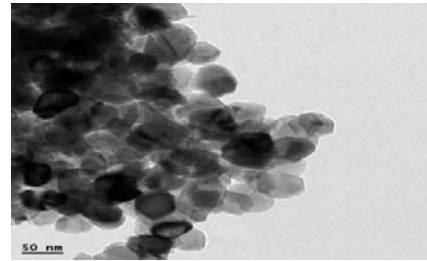

Fig 4(a) HRTEM micrograph (High magnification) of TiO₂

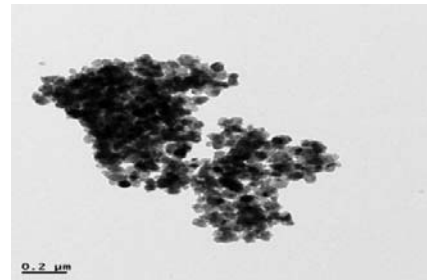

Fig 4 (b). HRTEM micrograph (Low magnification) of TiO₂



Fig 4 (c). SAED pattern for TiO₂

Fig 4(a) and (b) shows high and low magnification of a bright field transmission electron micrograph of TiO₂ nanoparticles obtained by sputtering process. It clearly displays the well dispersed spherical shape nanoparticles with a diameter ranging from 30 nm to 40nm. The crystallinity of the synthesized TiO₂ nanoparticle was verified using the Selected Area Electron Diffraction (SAED) pattern as

shown in fig 4(c). From the SAED pattern, the presence of ring corresponds to anatase and rutille phases of TiO₂ and confirms the polycrystalline nature.

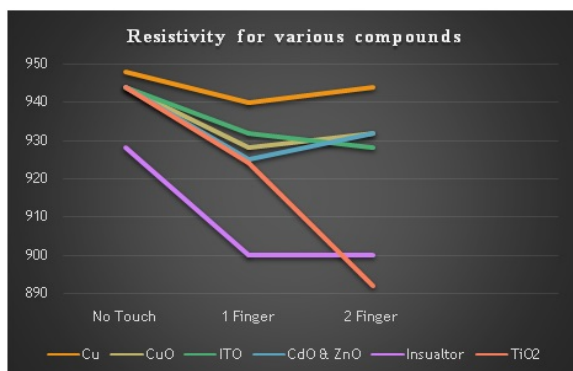

Fig 5: Line graph showing resistivity of various compounds

Data remains unchanged when the numbers of fingers are increased (more than 2). Fig. 5 explains the line graph of various compounds taken and plotted against their respective resistivity.

Table 2: Resistivity values for various kinds of touch for Cu

Kind of Touch	UV	Ordinary Light	White Light	Laser
No Touch	948	948	948	948
One Finger Touch	940	940	940	940
Two Finger Touch	944	944	944	944

Table 3: Resistivity values for various kinds of touch for CuO

Kind of Touch	UV	Ordinary Light	White Light	Laser
No Touch	944	944	944	944
One Finger Touch	928	928	928	928
Two Finger Touch	932	932	932	932

Table 4: Resistivity values for various kinds of touch for ITO

Kind of Touch	UV	Ordinary Light	White Light	Laser
No Touch	944	944	944	944
One Finger Touch	932	932	932	932
Two Finger Touch	928	928	928	928

Table 5: Resistivity values for various kinds of touch for CdO & ZnO

Kind of Touch	UV	Ordinary Light	White Light	Laser
No Touch	944	944	944	944
One Finger Touch	925	925	925	925
Two Finger Touch	932	932	932	932

Table 6: Resistivity values for various kinds of touch for Insulator

Kind of Touch	No Light	UV	Ordinary Light	White Light
No Touch	928	928	928	928
One Finger Touch	900	900	900	900
Two Finger Touch	900	900	900	900

Table 7: Resistivity values for various kinds of touch of TiO₂

Kind of Touch	UV	Ordinary Light	White Light	Laser
No Touch	936	940	940	940
One Finger Touch	924	920	920	920
Two Finger Touch	920	920	920	928

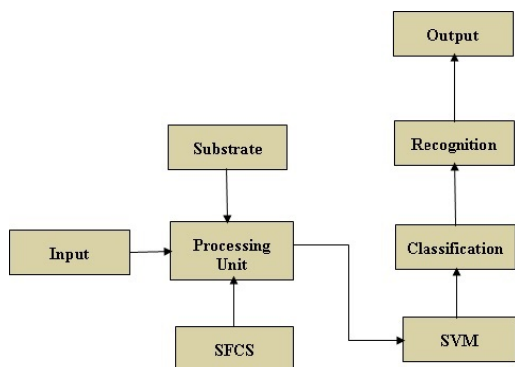

Fig. 6 Proposed Methodology for touch sensing

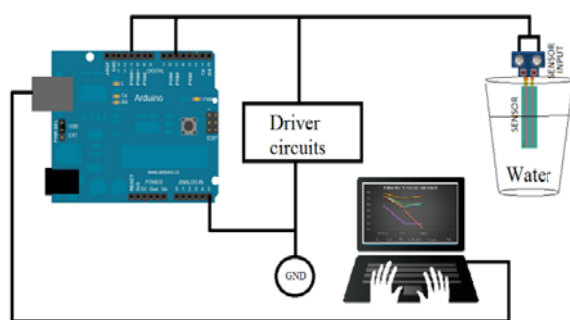

Fig. 7 Working setup

Fig. 6 explains the proposed technology and fig 7 discusses about the working setup of smart sensing using arduino. Arduino is open source and it is capable of sensing the environment by receiving inputs from many sensors and affects its surroundings by controlling lights, motors and other actuators. Here, the processing unit acts as the nucleus of the proposed methodology. Driver circuit amplifies the input data into the required format which the arduino is capable of receiving to produce the expected output. The input and the swept frequency are fed to the processing unit which passes the output to the classifier.

There are various classifiers available for classification. Each algorithm has its own properties and is best for classifying certain kinds of application only. SVM morpheme is used in this method. This does the process of classification and finds the kind of touch being made namely one finger dip, two finger dip etc., Here it is tested for water as a medium and in case of emergency air can be used as a medium. As the molecular mass increases with other medium the touch varies in accordance with that of molecular mass.

Here, various compounds namely Copper (Cu), Copper Oxide (CuO), ITO, combination of Cadmium Oxide (CdO) & Zinc Oxide (ZnO), insulator and Titanium Dioxide (TiO₂) [7,10] are checked for. All three kinds namely conductor, semi-conductor and insulator are tested upon. In this it is tested in two different ways: one is TiO₂

coated [11, 15] on metal and all other compounds coated on glass. The values are noted for various compounds coated on various substrates. It is found that all compounds coated on glass gives the same values irrespective of the light being passed.

But when TiO₂ [16,19] was tested by passing different lighting condition namely no light, white light, laser, UV and ordinary light it was noticed that the values changing based on the light passed. This proves that TiO₂ [20] has different characteristics for different light whereas other compounds react in the same manner irrespective of the light being passed. It can also be concluded that TiO₂ [20] would be the ideal choice when the lighting condition varies. When more than one set of data is being taken into consideration we need a classifier which is optimal in characterizing the exact data from the dataset.

5. Conclusion

The developed system smart sensing tells what kind of coating would make the user experience touch better. Touch screens have come into existence not only to view and operate with buttons but make it livelier by using touch as the interface for communication. It is only because of the lively approach; touch display has become a craze for people round the globe. This research work has taken touch based system a step ahead by choosing the kind of coating that could be used in any device where a display is necessary. It finds its applications in all electronic devices which are used in day to day activities. This could commonly be used in tablets and mobile phones where touch has reached the pinnacle. On comparing the various kinds of materials like conductor, semi – conductor and insulator coated on various surfaces like glass and metal it was found that TiO₂ would be suitable.

As the system used could recognize and take decision by itself is the smartness in smart sensing. The experiment was done not only on one kind of light source but also for various kinds of lighting effects like normal light, no light, ultraviolet, white light and laser.

References

- [1] Chitra Agashe, Oliver Kluth, Gunnar Schpe, Hilde Siekmann, Jrgen Hpkes and Bernd Rech, Thin Solid Films, **442**, 12 (2003)
- [2] E Fortunato, A. Goncalves, A. Pimentel, P. Barquinha, G. Goncalves, L. Pereira, I. Ferreira R. Martins, Applied Physics A Materials Science and Processing **96** (2009)
- [3] Hrvoje Benko, Andrew D. Wilson and Patrick Baudisch, ACM Digital Library (2006)
- [4] Hrvoje Benko, Andrew D. Wilson and Ravin Balakrishnan, ACM Digital Library (2008)
- [5] Jason Keleher, Jennifer Bashant, Nicole Heldt, Latasha Johnson and Yuzhuo Li, World Journal of Microbiology & Biotechnology **18** (2002)

- [6] Jeferson Y. Han, ACM Digital Library (2005)
- [7] Jiale Song, Zhimi Zhou, Chanchan Li, Dejin Cheng, J. Optoelectron. Adv. Mater. **16**(7-8), 873 (2014)
- [8] Ken Hinckley and Mike Sinclair, "Touch-Sensing Input Devices", ACM Digital Library (1999)
- [9] A.K. Kulkarni, Kirk H. Schulz, T.S. Lim, M. Khan, Thin Solid Films **345** (1999)
- [10] Mandeep Singh, Dinesh Pathak, Aman Mahajan, R. K. Bedi, J. Optoelectron. Adv. Mater. **14**(7- 8), 624 (2012)
- [11] D. Mardare, G. I. Rusu, J. Optoelectron. Adv. Mater. **6**(1), (2004)
- [12] Nandhini.K, N.R.Raajan, International Journal of Applied Engineering Research, **8**, 17 (2013)
- [13] Nandhini.K, N.R.Raajan, International Journal of Applied Engineering Research, **8**, 17 (2013)
- [14] Poulomi Roy, Stefen Berger, and Patrik Schmuki, A Journal of the Gesellschaft Deutscher Chemiker, **50**, 13 (2011)
- [15] Prabitha B. Nair, V. B. Justinictor, Georgi P. Daniel, K. Joy, K. C. James Raju, P. V. Thomas, J. Optoelectron. Adv. Mater., **16**(3-4), 360 (2014)
- [16] Qiming Liu, Xuan He, Xiaotao Sui, Benqiang Lu, Xiujian Zhao, J. Optoelectron. Adv. Mater., **14**(11- 12), 905 (2012)
- [17] J.L. Raheja, , A. Chaudhary, , K. Nandhini, S. Maiti, Signal, Image and Video Processing, Springer, 8, 2014.
- [18] Tadatsugu Minami, Thin Solid Films, 516, 7 (2008)
- [19] Tariq Mahmood, Chuanbao Cao, R. Ahmed, M. A. Saeed, Maqsood Ahmed, J. Optoelectron. Adv. Mater. **16**(1-2), 117 (2014)
- [20] Yongquan Qing, Yansheng Zheng, Chuanbo Hu, Yong Wang, Yi He, Qian Mo, **16**(1- 2), 60 (2014)
- [21] Zhong Lin Wang, Journal of Physics: Condensed Matter, **16** (2004)

*Corresponding author: rkkarn@ece.sastra.edu