

Switching power improvement of hybrid polymer-silica based MMI thermo-optical switch

M. YAACOB, M. H. IBRAHIM*, N. M. KASSIM, A. S. MOHD SUPA'AT, A. B. MOHAMMAD
*Photonics Technology Centre, Faculty of Electrical Engineering, Universiti Teknologi Malaysia
81310 Skudai, Johor, Malaysia*

A new hybrid polymer-silica multimode interference (MMI) switch with single heater electrode is demonstrated. A heater electrode is used to change the refractive index within the different section of the MMI to realize switching operation due to the thermo-optic (TO) effect in polymer-silica optical waveguide. Switching power analysis has been done by employing straight heater electrode followed by implementation of trapezoidal structure. The simulation result shows that the trapezoidal structure of heater electrode helps to achieve significant improvements of MMI switch performance particularly in switching power reduction by 33.37% as compared to the rectangular structure.

(Received May 5, 2009; accepted May 25, 2006)

Keywords: BenzoCyclobutene polymer, multimode interference, optical coupler, tapered electrode heater, optical switch

1. Introduction

Recently, it is utmost desirable for the developed optical switch to portray low switching power in order to meet current requirement of high speed and high capacity optical network. As such, various works have been initiated to meet this issues including work by Moyer, *et al.* [1] that manage to obtain low switching power by applying two symmetric electrodes and work by Xiang Wu, *et al.* [2], had demonstrated the application of tapered heater electrode to produce lower electric power consumption.

In the past couple of years, the most widely investigated optical switches have been demonstrated by several approaches such as directional coupler based switch [3], Mach-Zehnder interferometer (MZI) based switch [4], Y-branch based switch [5], multimode interference (MMI) based switch [6-8] and combination of MMI-MZI based switch [9]. Among of this approaches, MMI based switch are becoming more popular due to their excellent properties and easiness of fabrication. Their main advantages are ultra-compact size, low loss and large fabrication tolerances [10].

Most of the tuning or switching methods of MMIs are based on the carrier-related electro-optic effect [11, 12] and thermo-optic effect [13]. The MMI optical switches based on thermo-optic control are very attractive due to their simplicity and flexibility. The thermo-optic effect refers to the variation of the refractive index of a heated dielectric material. By tuning the refractive index directly within different sections of the MMIs, the refractive index modifications lead to the variations of the effective MMI regions or the self-image phases within the MMIs.

Consequently, the position of the output images can be changed which further realize the switching operation.

Polymer material has been regarded as one of the main materials that exhibit the thermo-optic effect that can be further manipulated to be applied in the development of thermo-optic switch. This is due to the significant advantages offered by this material such as low thermal conductivity and greater temperature dependence of refractive index [7].

In order to realize a high performance optical switch, the main factor needs to be considered is switching power. In this paper, we focus on investigating the effect of heater electrodes in terms of position and geometrical structure to achieve low switching power consumption. Firstly, the straight heater electrode structure has been designed with optimum location and strip width to obtain low switching power and highest extinction ratio. Then, the analysis followed by trapezoidal structure which is tapered at initial width of heater electrode. From the simulation, it shows that the trapezoidal structure is superior in which simulated figure of switching power has been significantly improved by 33.37%.

2. Operation principle and device structure

The basic architecture of proposed optical switch is designed according to the 2x2 MMI based cross coupler. The property of MMI coupler is based on the principal of the self-imaging effect [14, 15]. The principal can be stated as the input is reproduced in single or multiple image at periodic intervals along the propagation direction of the guide [10]. Two types of self-imaging mechanism has been discussed in detail by Soldano and Pennings [10]

known as *general interference* (GI) and *restricted interference* (RI). In RI, the MMI device can be designed either by paired or symmetric interference MMIs depending on the field excitation condition. For paired interference scheme, the input access waveguide have to be placed at 1/3 or 2/3 of the MMI section width.

Due to the mode excitation in MMI section, the interference among these modes will produce single or multiple self image of the input field at certain distance. Regarding to paired interference, the direct and mirrored single images of the input field will be formed at the multimode section length of:

$$L = p(L_{\Pi}) \quad (1)$$

where p is even or odd integer, respectively. The direct and mirrored single images correspond to bar and cross-coupling state, respectively. L_{Π} is defined as the beat length of the two lowest order modes and can be written as:

$$L_{\Pi} = \frac{\Pi}{(\beta_0 - \beta_1)} \quad (2)$$

where β_0 and β_1 are the propagation constant of the fundamental and first order modes, respectively. In our work, a hybrid polymer-silica has been applied in designing the 2×2 MMI based cross coupler. The MMI structure consists of BenzoCyclobutene (BCB 4024-40) polymer as core layer surrounded by silica (SiO₂) upper cladding and BK7 lower cladding. The refractive indices of BCB 4024-40 polymer, SiO₂ and BK7 glass are 1.5556 [16], 1.45 [17] and 1.50101 [18], respectively.

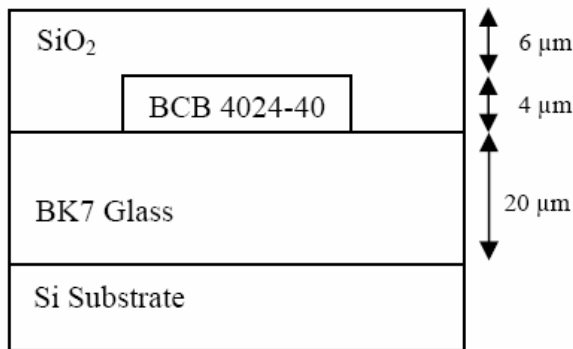

Fig. 1. Cross section of the MMI based cross coupler.

The MMI structure was layered by deposition of 4μm thick of core, 6μm thick of upper cladding and 20μm thick of lower cladding. A silicon wafer was used as substrate layer. The two-dimensional view of MMI structure is illustrated in Fig. 1.

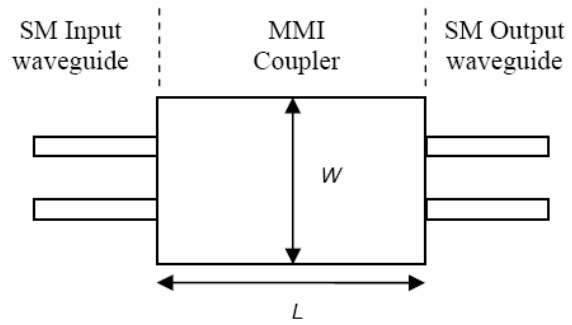

Fig. 2. Layout of the MMI cross coupler

In view of the MMI structure, it consists of two single mode access waveguide entering the input end of MMI coupler as shown in Fig. 2. The dimension of the single mode (SM) access waveguide is 4×4 μm². An MMI coupler is set to have a slab width, W of 50 μm wide. By employing equation (1), the calculated optimum coupler length, L is 3580 μm.

3. Heater electrode design and analysis

Switching between the output ports can be induced by changing the effective refractive indices within the different section of MMI region. Since the refractive indices are temperature dependence, the difference in refractive indices can be achieved which result from external thermal effect. This can be done by employing a heater electrode that is positioned at the top of upper cladding layer. Therefore, the main emphasize of this work will be on the analysis of different geometrical structure of the heater electrodes towards switching power curve. As such, two types of electrodes have been chosen which are a straight rectangular heater and a trapezoidal structure.

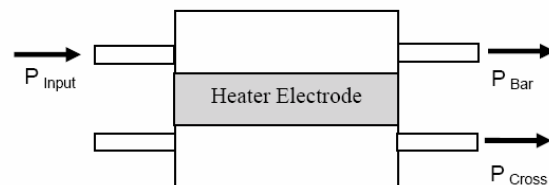
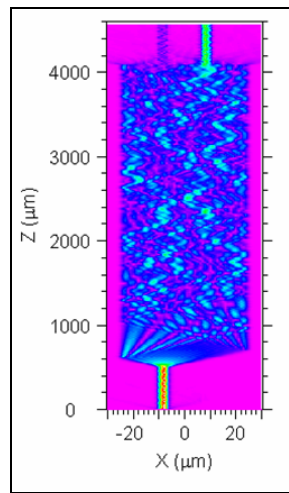

Fig. 3. Schematic configuration of the thermo-optic MMI switch with a straight heating electrode.

The analysis begins with a straight heater electrode structure. 2000 Å-thick aurum was shaped as a straight heater on top of upper cladding layer. The heater is optimized to be 7 μm wide and 3580 μm long, corresponding to the length of MMI coupler as depicted in Fig. 3. The heater size selection is discussed in section 4.0. In addition, the heater electrode is located at that particular

position, such as to prevent light propagation at selected MMI region when external TO effect is applied. Without thermal tuning, the structure operates like normal cross coupler. Therefore, the light will emit at output port P_{Cross} when input light at the wavelength of 1550nm is fed from input port P_{Input} . However, as electric power is applied to the electrode heater, the refractive index beneath the electrode will decrease due to the negative TO coefficient of the polymeric materials. From this condition, the idea in putting the electrode at the centre along of MMI length leads to the prevention of light propagation onto the output port P_{Cross} . As a result, major light confinement will shift to the output port P_{Bar} . Thus, optical switching can be achieved. Fig. 4(a) and (b) shows the optical power distribution in which no heat is applied and the heater is powered, respectively.



a

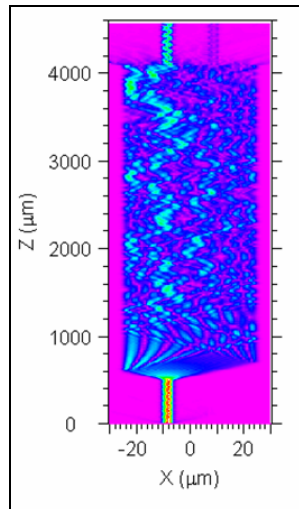

b

Fig. 4. Beam Propagation Method (BPM) analysis of MMI switch for optical power distribution (a) without thermal tuning and (b) with thermal tuning.

The essential parameters used during the simulation phase are listed in Table 1. Considering the substrate as a perfect heatsink, the temperature distribution in the waveguide layer when power is applied at heater electrode is visualized in Fig. 5.

Table 1: Thermal properties of material used in the proposed MMI optical switch.

Material	Thermal Conductivity, (W/m.K)	Thermal Coefficient
BCB-4024 Polymer	0.29 [16]	$-1.5 \times 10^{-4} / \text{K}$ [16]
SiO ₂	1.4 [17]	$8 \times 10^{-6} / \text{K}$ [17]
BK7 Glass	1.114 [18]	$1.1 \times 10^{-6} / \text{K}$ [18]
Silicon Substrate	163.3 [19]	$160 \times 10^{-6} / \text{Celsius}$ [19]

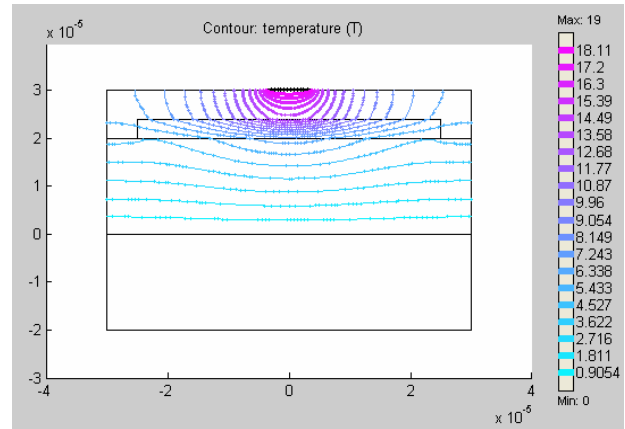

Fig. 5. Temperature distribution in which the straight heater is powered by 0.065 W.

For further investigation of the switching power in MMI switch, a tapered heating electrode was proposed. The dimension of MMI structure and heater position is set to be equal to the device layout in Fig. 1 and Fig. 3, respectively. As demonstrated in Fig. 6, the initial width, W_1 of tapered heater are 4 while the final width, W_2 μm is fixed to 7 μm . This heater size selection is thoroughly discussed in section 4.0.

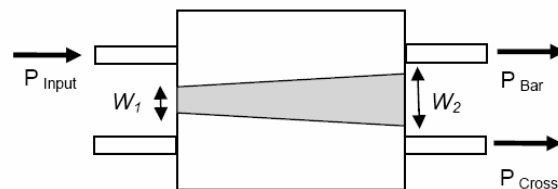

Fig. 6. Schematic configuration of the thermo-optic MMI switch with a thin tapered heating electrode.

In order to find out power consumption of tapered heater electrode, we need to derive the expression for resistor with trapezoidal shape. The governing expression for R for a resistor of arbitrary shape is given by [20]:

$$R = \frac{V}{I} = \frac{\int E \cdot dl}{\int \sigma E \cdot ds} \quad (\Omega) \quad (3)$$

where

- σ = material conductivity of heater electrode
- E = electric field of an infinite line of charge
- l = integration path between two specified point on length of heater electrode
- s = cross section of heater electrode

By solving equation (3), the total power consumption for a tapered heating electrode with applied electric power can be written as:

$$Power = RI^2 = \frac{\rho Lc}{(w_2 - w_1)h} I^2 \ln\left(\frac{w_2}{w_1}\right) \quad (\text{Watt}) \quad (4)$$

where

- ρ = resistivity of the heater electrode
- L_c = length of the heater electrode
- I = current through the heater electrode
- h = thickness of the heater electrode
- w_1 = initial width of the heater electrode
- w_2 = final width of the heater electrode

4. Results and discussion

In order to compare the performance of proposed tapered heater electrode with original straight structure, both designs were simulated simultaneously. The simulation was done using BeamProp software from RSoft®, which based on Finite Deference Beam Propagation Method (FD-BPM). Fig. 7 presents the switching characteristic of the proposed MMI switch with straight heater electrode.

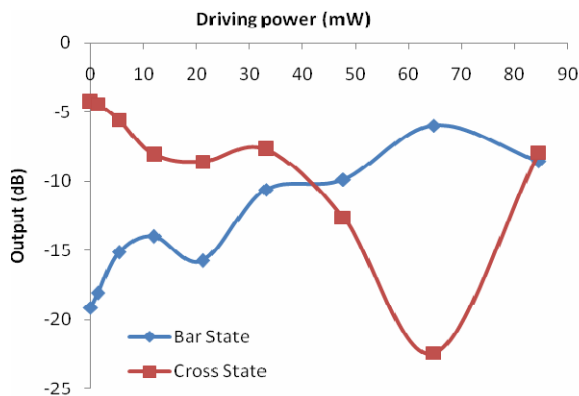

Fig. 7. Switching characteristics of the MMI switch with the straight heating electrode.

In a passive coupler operation, cross state has an insertion loss of 4.24 dB while bar state has insertion loss of 19.1 dB which provide an extinction ratio of 14.86 dB. At a driving power of 64.78 mW, switching operation occurred with cross state has insertion loss of 22.4 dB and bar state has insertion loss of 5.96 dB which produced an extinction ratio of 16.45 dB.

The switching performance with different strip width towards extinction ratio and driving power were computed as well. Fig. 8 shows the extinction ratio as the function of strip width. From the graph, it was observed that the extinction ratio oscillating with increasing strip width when varied from 4 μm to 10 μm. A 7 μm wide of strip width was selected for straight heater electrode to produce an MMI switch, due to the highest extinction ratio level of 16.45dB. However, as can be observed from Fig. 9, the chosen strip width does not exhibiting low switching power as expected. Therefore, a trapezoidal heater shape was proposed to improve the results obtained from the previous simulation particularly in the switching power aspect.

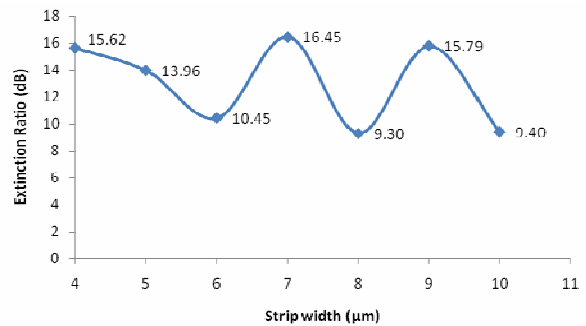

Fig.8. Extinction ratio versus the width of a straight heater.

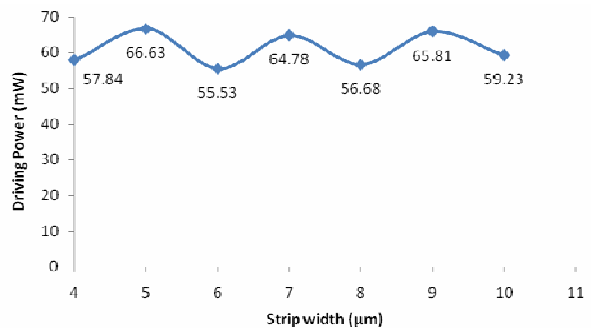

Fig. 9. Driving power versus the width of a straight heater.

For trapezoidal heater shape, a slight modification was done at initial width of heater electrode. In order to determine the optimum size of trapezoidal shape, the analyses are carried out for different initial width to investigate its effect on the extinction ratio and driving power. For these analyses, the final width of tapered heater is 7 μm while the initial width varies from 3 μm to 7 μm. The initial width as the function of driving power has been

plotted in the graph as shown in Fig. 10. From the graph, the driving power is increases with the increasing initial width, thus smaller initial width is preferable to achieve low switching power.

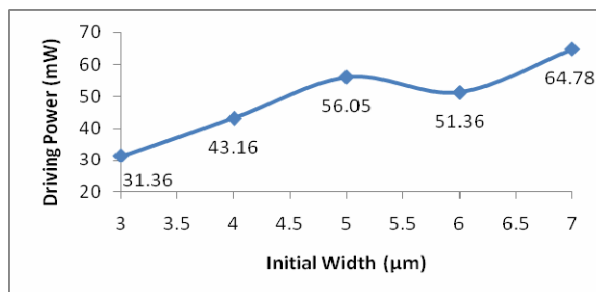

Fig. 10. Driving power versus the initial width of a tapered heater.

Meanwhile, different size of initial width also influences the extinction ratio performance as shown in Fig. 11. Hence, proper choice of initial width's size is a prerequisite in order to obtain excellent performance of both switching power and extinction ratio. Therefore, initial width of 4 μm was selected to fulfill both requirements which produce a heater electrode with low switching power and high extinction ratio.

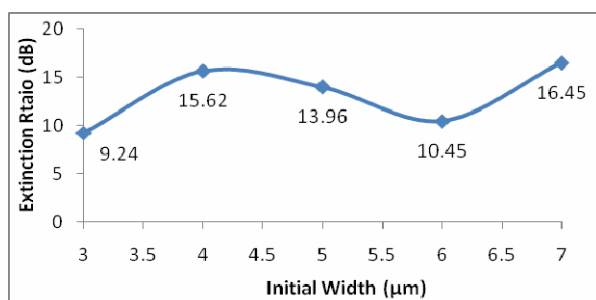

Fig. 11. Extinction ratio versus the initial width of a tapered heater.

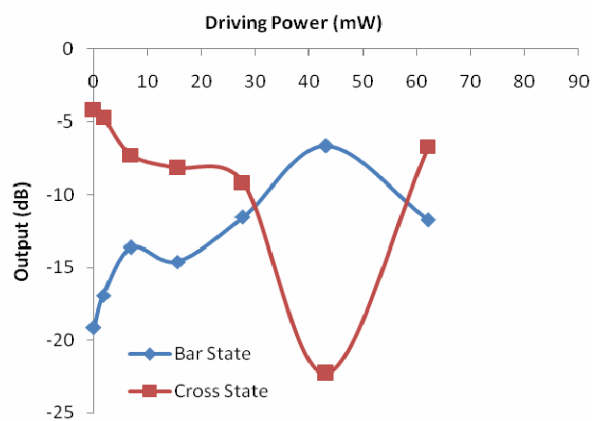

Fig. 12. Switching characteristics of the MMI switch with the tapered heating electrode.

The simulated switching characteristic for the pre-designed trapezoidal heater shape is represented in Fig. 12. The driving power at 43.16 mW produced extinction ratio of 15.62 dB. Note that the trapezoid electrode has the advantage of reducing switching power up to 33.37% instead of a straight one.

In view of previous research, the only significant work has been reported by Wu, *et al.* [2] that demonstrated the application of tapered heater in 1×2 thermo-optical switch based on organic-inorganic sol-gel material. As reported [2], the measured switching power using straight and tapered heater are 0.16 W and 0.084 W, respectively which definitely portray the advantage of using the tapered heater structure. As compared to our work, similar approaches of designed heater have been applied, but the material used is quite different. Nevertheless, with the simulated switching power improvement of 33.37%, it greatly portrays the competitiveness of our proposed hybrid polymer/silica material in combination with the tapered heater electrode structure in optical switch realization.

5. Conclusion

In this work, a hybrid polymer-silica based MMI thermo-optical switch has been successfully designed. Two types of heater electrode structure; rectangular and trapezoidal, have been designed, optimized and testified for its simulated performance. It was observed that employment of trapezoidal heater structure can reduce the applied switching power by 33.37% as compared to its counterpart. Comparison with other polymer based MMI switch indicates that our proposed MMI switch with hybrid BCB 4024-40 polymer-silica is competitive in power consumption and extinction ratio.

Acknowledgments

This work was partially supported by Ministry of Higher Education of Malaysia under Fundamental Research Grant Scheme and Nippon Sheet Glass Foundation for Materials Science and Engineering under Overseas Research Grant Scheme.

References

- [1] P. J. Moyer, S. A. Pridmore, F. Farahi. Optical Engineering, **43**(1), 165 (2004).
- [2] Xiang Wu, Liying Liu, Yanwu Zhang, Dongxiao Li, Wencheng Wang, Lei Xu. Optics Communications, **258**(2), 135 (2006).
- [3] Abu Sahmah Mohd Supa'at. Design and fabrication of a polymer based directional coupler thermo-optical switch. Universiti Teknologi Malaysia: Phd Thesis (2004).
- [4] Yasuyuki Inoue, Katsumi Katoh and Masao Kawachi. IEEE Photonics Technology Letters, **4**(1), 36 (1992).
- [5] Dong-Min Yeo, Sang-Yung Shin. Optics Communications, **267**(2), 388 (2006).

- [6] Abdulaziz M. Al-hetar, I. Yulianti, Abu Sahmah M. Supa'at, A.B. Mohammad, *Optics Communications*, **281**(18), 4653 (2008).
- [7] Fan Wang, Jianyi Yang, Limei Chen, Xiaoqing Jiang, Minghua Wang. *IEEE Photonics Technology Letters*, **18**(2), 421 (2006).
- [8] M. H. Ibrahim, Mee-Koy Chin, N. M. Kassim, A. B. Mohammad. *Chinese Physics Letters*, **23**(10), 2796 (2006).
- [9] Q. Lai, W. Hunziker And H. Melchior. *IEEE Photonics Technology Letters*, **10**(5), 681 (1998).
- [10] Lucas B. Soldano And C. M. Penning. *Journal Of Lightwave Technology*, **13**(4), 615 (1995).
- [11] D.A. May-Arrijoja, N. Bickel and P. Likamwa. *Optical and Quantum Electronics*, **38**(7), 557 (2006).
- [12] Juerg Leuthold and Charles H. Joyner. *Journal of Lightwave Technology*, **19**(5), 700 (2001).
- [13] Bo Asp Moller, Lars Jensen, Christian Luarent-Lund and Carsten Thirstrup. *IEEE Photonics Technology Letters*, **5**(12), 1415 (1993).
- [14] O. Bryngdahl. *Journal of the Optical Society of America*. **63**(4), 416 (1973).
- [15] R. Ulrich and G. Ankele. *Applied Physics Letters*. **27**(6), 337 (1975).
- [16] The Dow Chemical Company. *Product Literature: Cyclotene™ Advanced Electronic Resins*, (1999).
- [17] Weyl-kuo Wang, Hyung Jong Lee and P.J. Anthony. *IEEE Journal of Lightwave Technology*. **14**(3), 429 (1996).
- [18] Mohd Haniff Ibrahim. *Polymer Based Multimode Interference Optical Devices*. Universiti Teknologi Malaysia: PhD Thesis (2007).
- [19] Schott AG *Optical Glass Datasheet*.
- [20] Fawwaz T. Ulaby, "Fundamentals of applied electromagnetic", Prentice Hall, (1999).

*Corresponding Author: hanif@fke.utm.my